

**EAST  
DAVISON  
VILLAGE**

# **EDGING FRAMEWORK PLAN**

**CITY OF DETROIT**  
Mayor Michael Duggan



**PLANNING AND  
DEVELOPMENT DEPARTMENT**



**EAST  
DAVISON  
VILLAGE**

# **EDGING FRAMEWORK PLAN**

**Planning and Development Department  
City of Detroit, November 2020**

# ACKNOWLEDGEMENTS

We greatly appreciate the many community residents, organizations, and other stakeholders that provided their ideas and guidance throughout the planning process.

## **CITY OF DETROIT**

Planning & Development Department (PDD)  
Detroit Land Bank Authority (DLBA)

## **CONSULTING PARTNERS**

TEN x TEN, lead  
D.I.R.T. Studio  
Peter Del Tredici  
Global Detroit

## **COMMUNITY PARTNERS**

East Davison Village Community Group



# TABLE OF CONTENTS

<b>01 INTRODUCTION</b>	<b>7</b>
The Edging Framework Plan	
Project Mission	
Community Driven	
What is an Edge?	
Neighborhood Stewardship	
A Neighborhood Quilt	
Four Key Ideas	
How to Use the Plan	
<b>02 LOT ASSESSMENT TOOL</b>	<b>29</b>
Lots vs. Edges	
Policies + Programs	
Context	
Assessing Trees and Vegetation	
Maintenance and Management	
Evaluate Your Lot	
<b>03 EDGE DESIGN GUIDELINES</b>	<b>53</b>
Decision Spectrum	
Before you Start Instructions	
Edge Designs and Construction Diagrams	
<b>04 GLOSSARY</b>	<b>123</b>
Material Library	
Key Terms and Definitions	
Stencil Templates	
Section and Plan Templates	





**EAST  
DAVISON  
VILLAGE**

**01**

# **INTRODUCTION**

**EDGING  
FRAMEWORK  
PLAN**

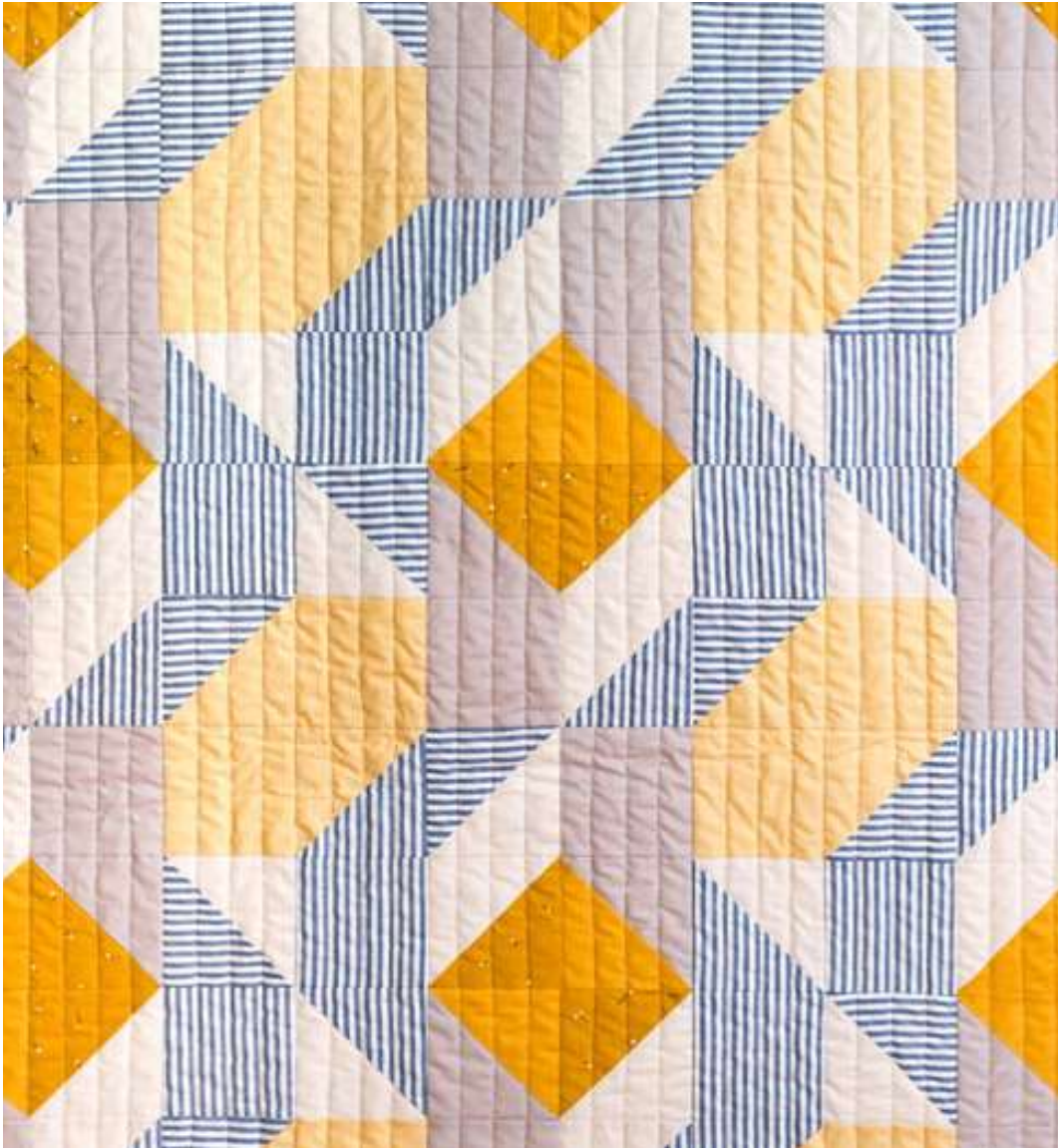



# The Edging Framework Plan

***The Edging Framework Plan can be used to implement landscape interventions at the edges of lots to build a neighborhood-wide system of improvements that activate, connect and create identity.***

Vacant land in cities can be a destabilizing force, attracting illegal dumping and crime, diminishing property value and impacting the image of the neighborhood. Vacant land can also create unprecedented opportunities for residents to build social, environmental and economic capital to celebrate and showcase the unique local identity of their neighborhood.

The East Davison Village Edging Framework Plan establishes guidelines to improve privately-owned properties, building upon the Campau/Davison/Banglatown Neighborhood Framework Plan to catalyze neighborhood connections through smaller, more affordable “edge” improvements. Over time, these smaller improvements will stitch the neighborhood together, like a quilt, strengthening connections, increasing ecological resilience and function, and providing places for people to gather, play and share ideas.

This plan is intended to be flexible and provide design ideas, maintenance and management strategies, and implementation guidelines to connect and activate East Davison Village. The plan is organized into four chapters:

**Chapter 1: Introduction**

**Chapter 2: Lot Assessment Tool**

**Chapter 3: Design Guidelines**

**Chapter 4: Glossary**



# Project Mission

***The mission of the Edging Framework Plan is to increase ecological and social resilience of the East Davison Village community through a system of implementable designs for lot edges that connect people together and celebrate their identity.***

## DESIGN

Through instructions and guidelines, this plan provides designs for a range of improvements including: gardens, ground surfaces, furniture, and features. Using specific materials, a color palette, and stencils, the elements celebrate East Davison Village's unique identity.

Design components can be paired together or constructed alone, creating a wide range of possibilities.

## PLANNING

The document will provide lot plan and section templates to use as you design your edge (see page 130-131). It will help guide the planning process by offering decision-making prompts and providing information about where to find relevant city-wide policies, zoning ordinances and DLBA programs.

This plan is grounded by the proposed Open Space and Community Nodes network in the Campau/Davison/Banglatown Neighborhood Framework Plan and organizes specific edge types to help connect community nodes and open space assets.

## MANAGEMENT

With regard to the expansive stewardship efforts of East Davison Village community members, this plan provides an approach to management and maintenance that works with "disturbance-adapted" plants. This plan provides guidance on how to identify, maintain, and manage hardy spontaneous plants that grow without human intervention, including both native and non-native species. These "spontaneous" plants provide substantial ecological services at relatively low cost.

## A LIVING DOCUMENT

This document is intended to be 'living' in that it can be referred back to and remain relevant over time. Design components in the Edging Framework Plan can be mixed and matched as lot-owners want to add to change their edges. Community members are encouraged to keep the assets and stewardship maps up-to-date as the neighborhood edges continue to expand through the community.



This plan will work to accomplish the following goals and objectives identified by community members:

## GOALS

**INSPIRE STEWARDSHIP**

**ACTIVATE EMPTY LOTS**

**IMPROVE MAINTENANCE**

**DETER ILLEGAL DUMPING**

**CREATE SPACES FOR EVENTS**

**SIMPLIFY LOT ACQUISITION**

**CREATE UNIQUE IDENTITY**

**CREATE SAFE SPACES**

**DRAW NEW NEIGHBORS**

**STRENGTHEN BODY AND SPIRIT**

**CREATE PLACES FOR CHILDREN**

**WELCOME VISITORS**

**CREATE PLACES TO SIT**



## OBJECTIVES

- Clearly define what an “edge” is
- Collaborate with the community on design ideas that address these concerns
- Provide implementation guidelines and “How-to” instructions
- Create an asset map showing who has what skills, tools, and equipment for community collaboration
- Provide cost, resources/skills and tools required for various projects
- Provide time and effort required for various projects
- Provide maintenance and management guidelines
- Reflect community feedback such that our unique identity shines through the designs
- Transform lots such that renewed investment can attract more resources



# Community Driven

***The Edging Framework Plan was developed in collaboration with the East Davison Village Community Group (EDVCG) and neighbors through events, focus groups, and interviews.***

Building upon the engagement that resulted in the Campau/Davison/Banglatown Neighborhood Framework Plan, this planning effort seeks to create implementable projects and strategies that will be meaningful to the East Davison Village community, working to strengthen and support the existing community-driven initiatives.

The design and engagement process for the Edging Framework Plan was co-developed with the East Davison Village Community Group, an active block club turned non-profit organization, with a mission to provide empowerment and self-reliance for its members and attract resources to the neighborhood.

EDVCG provided guidance and ideas through a series of focus group meetings, site tours and phone interviews. EDVCG members co-facilitated and co-led all community events.



## Community Goals:

1. IDENTITY AND SIGNAGE
  - Create a clear and unique identity
  - Welcome visitors and show pride
2. SEATING (AND IDENTITY)
  - Create places to sit and gather
  - Create unique furniture
3. PLAY AND FITNESS
  - Create places for children
  - Create opportunities for fitness
4. SAFETY
  - Prevent dumping
  - Create safe connections
  - Clean up alleys and overgrown lots
5. ENTREPRENEURSHIP
  - Create spaces to host events
  - Create opportunities for exchange



**Focus Groups**



**Walking Tours**



**Community Events + Three Seed Projects (2020 Installations)**



# What is an Edge?

Edges are the outermost areas on your lot. They are the boundary along the street, the alley, or the sides of your property neighboring other lots. The size and dimension you choose for an edge improvement will depend on the context of the lot, existing conditions (*Chapter 2: Lot Assessment Tool*), your budget and resources. The “size” of your edge can range from 5’-30’ and shall be determined by you.

Edge improvements have the power of becoming a shared neighborhood resource. Because they will be located on the edges of a private property adjacent to a public sidewalk, street, or alley, they offer the potential of benefiting everyone and serving as a communal civic edge.



# What are the benefits?

## *Edges Can...*

- Connect and link spaces together
- Build identity and pride
- Support health and wellness
- Be beautiful
- Be a place to relax
- Be a place to play
- Be a place to gather
- Be a space for learning
- Be a place for entrepreneurship
- Be places for conversation
- Inspire more stewardship
- Improve property values
- Deter dumping
- Build interpersonal relationships



***Precedent Images***



# Existing Edge Conditions

There are five typical existing edge conditions, see Chapter 2: Lot Assessment Tool for more details. The edge designs in Chapter 3: Design Guidelines can be mixed and matched with any existing edge condition.

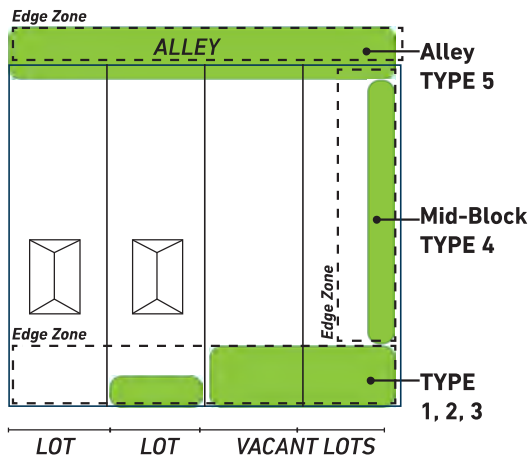

Edges can range in size from 5'-30' deep, starting at the interior edge of the sidewalk for street-facing edges or the property line for Type 4 edges. Alley Edges are a 'Build at Your Own Risk' zone; they could be ruined if the city needs to perform utility updates in your alley.

## SETBACKS

A "setback" is the required buffer distance along the edge of your property where there are limitations on what can be built and how that space can be used. Measure the distance from the edge of your property to the area you want to change before installing anything to ensure you are in compliance with the zoning ordinance.

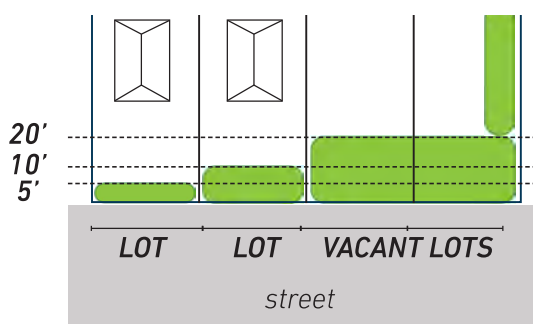

**10' or greater from the street:** Constructed elements, structures, and all garden types are allowed.

**5-10' from the street:** Mowed edges and low to medium height formal gardens are allowed in this zone.

**0-5' from the sidewalk or property line:** Mowed edges and low, formal gardens are allowed in this zone.





# Edges can be **stitched together** in many ways

When edges begin to populate the neighborhood, they will create a system of connective threads. These threads can wrap corners, traverse alleys, and connect through blocks across the neighborhood. As the number of edge improvements increase and grow a network of gardens and activated spaces, their impact on the neighborhood will grow as well.

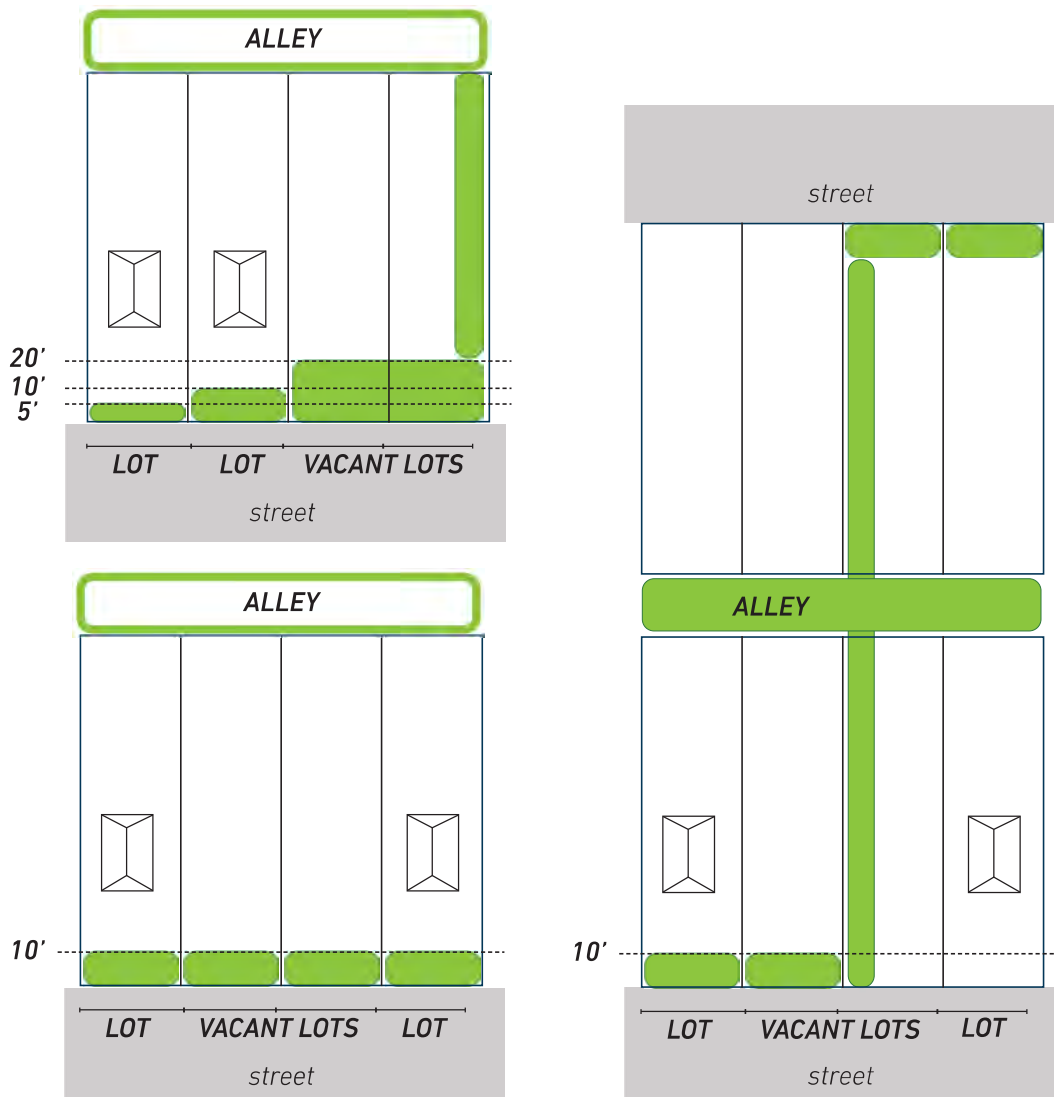

# Land Stewards



**Land Stewardship Map and Places of Promise**



# Places of Promise

The Land Stewardship Map was initially developed for the Campau/Davison/Banglatown Neighborhood Framework Plan and shows both ownership status and which lots neighbors are caring for. This map has been an important tool for the Edging Framework Plan and has been updated (p.18) through Focus Groups and Community Events to reflect the most current stewardship status.

The community identified “places of promise”, or important landmarks such as 20 Books, the Community Hub, Carmen’s Community Mini-Mart and the Bandhu Gardens, that already exist or are coming in the future, can serve as anchors for improvements. These places are magnets in the community that draw people together. Organizing the Edging Framework Plan around these assets in the neighborhood will mutually benefit existing and new investment.



**20 Books**



**Carmen’s Community Mart**

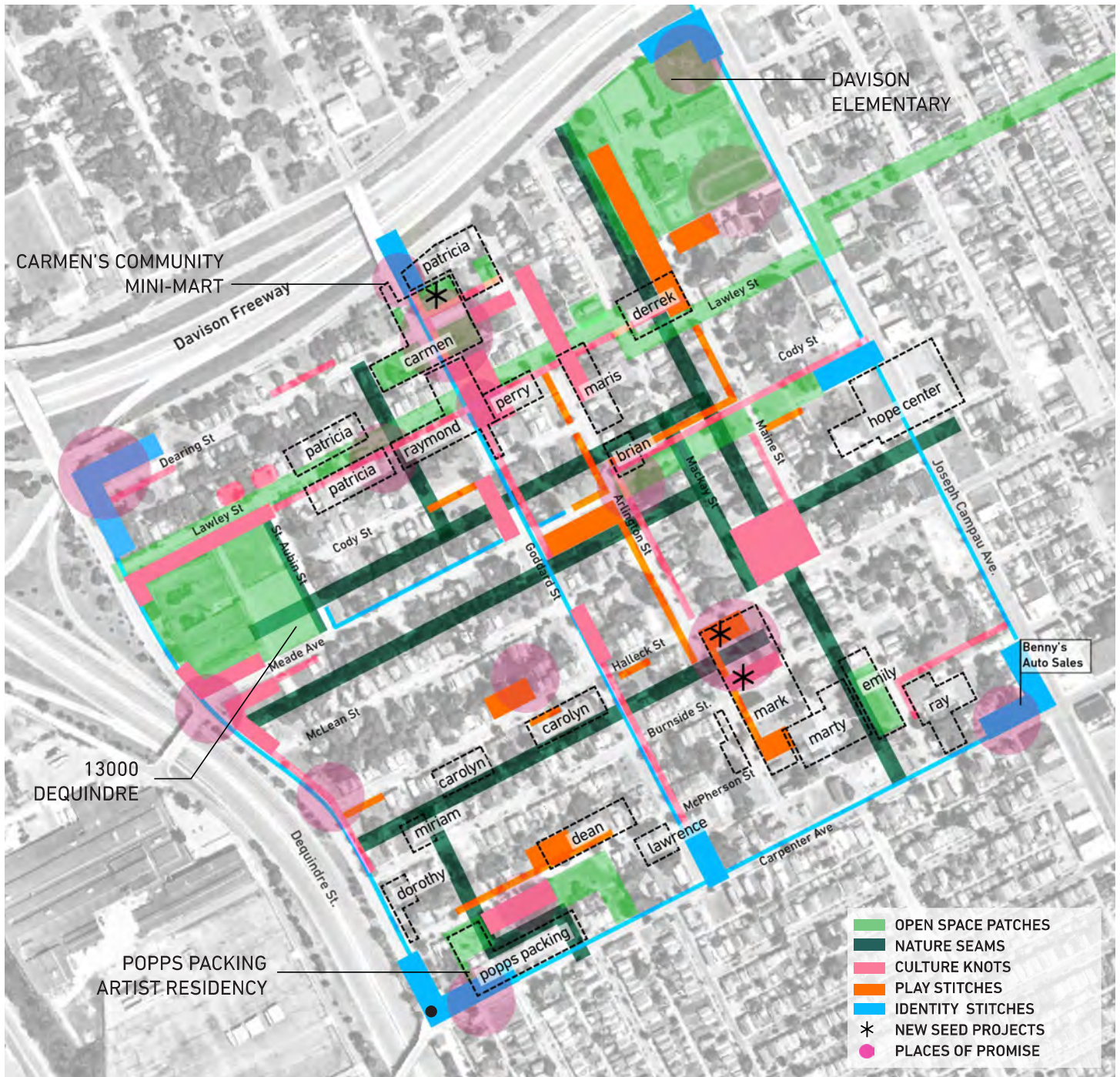

*Image: Bandhu Gardens*

**Bandhu Gardens**



# A Neighborhood Quilt



## ***The people, stories, and landscape of East Davison Village create a neighborhood quilt, unique with its own identity and pattern.***

A neighborhood “quilt” suggests that as edge improvements accumulate throughout the neighborhood over time, they create a resilient blanket of patches, seams, knots, and stitches. This new quilt made up of gardens, gathering spaces, and places to play and share, that celebrates the identity of this neighborhood is the essence of the Edging Framework Plan. The plan offers a suggestion for how different typologies might be organized within the “quilt” to help connect places of promise and neighborhood anchors together. Ultimately, the unique pattern that emerges will be created by individual and collective decisions made by you and your neighbors.

The Edging Framework Plan or “Neighborhood Quilt” is organized into the following components:

- Open Space **PATCHES**: Shown in light green is the Open Space Network proposed in the Campau/Davison/Banglatown Neighborhood Framework Plan.
- Nature **SEAMS**: Nature seams are where GARDEN typologies can be implemented in a higher density and across multiple lots to improve and enhance the unique disturbance-adapted vegetation that provides significant ecological function for the neighborhood.
- Culture **KNOTS**: Places or nodes that are well suited to accommodate GATHER and EXCHANGE typologies have been identified by community members. These nodes are located in highly visibly, heavily trafficked and centralized areas to maximize access. These edge types are well suited for multi-lot interventions.
- Play **STITCHES**: Places where PLAY typologies are suggested are centralized for easy access to the entire neighborhood and on mid-block lots where children are more protected from vehicular activity at intersections.
- Identity **STITCHES**: Locations for IDENTITY typologies and improvements should be integrated throughout the neighborhood, across multiple lots, and across various elements (benches, the stage, seats, etc). The community suggested that signage gateways anchor the four corners of the neighborhood and be integrated along Goddard Street to welcome people driving through the neighborhood.



# Edges are a **system** that can **grow** over time

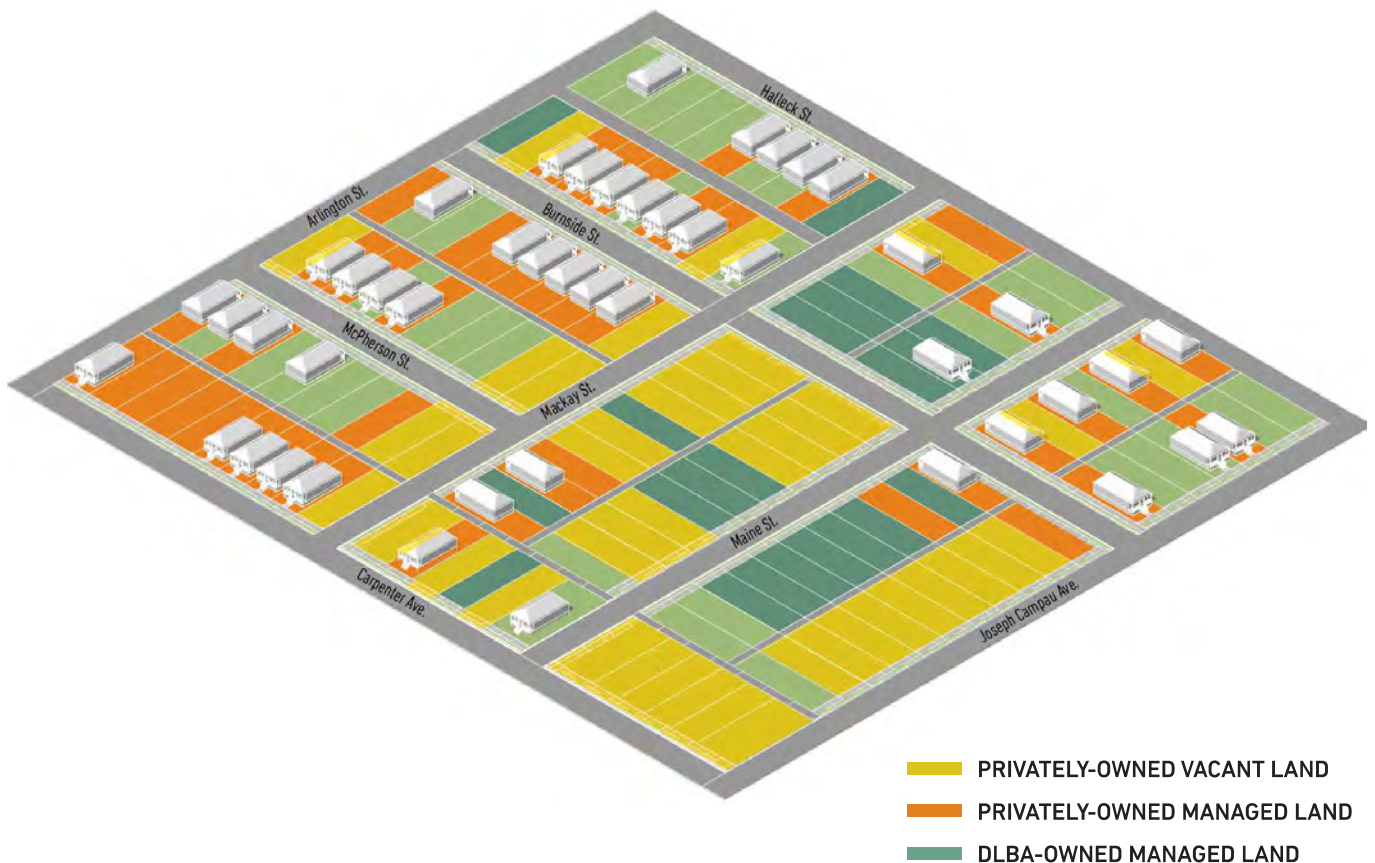

## BEFORE

East Davison Village is currently a collection of privately-owned vacant land, privately-owned managed land, and land owned by the Detroit Land Bank Authority (DLBA). Between the current privately-owed lots and lots that can be acquired in the future, there is huge potential to build a quilt of edges that create moments of beauty, places to play, to rest, and to gather.



Edges can be **mixed + matched** to create a **dynamic fabric**

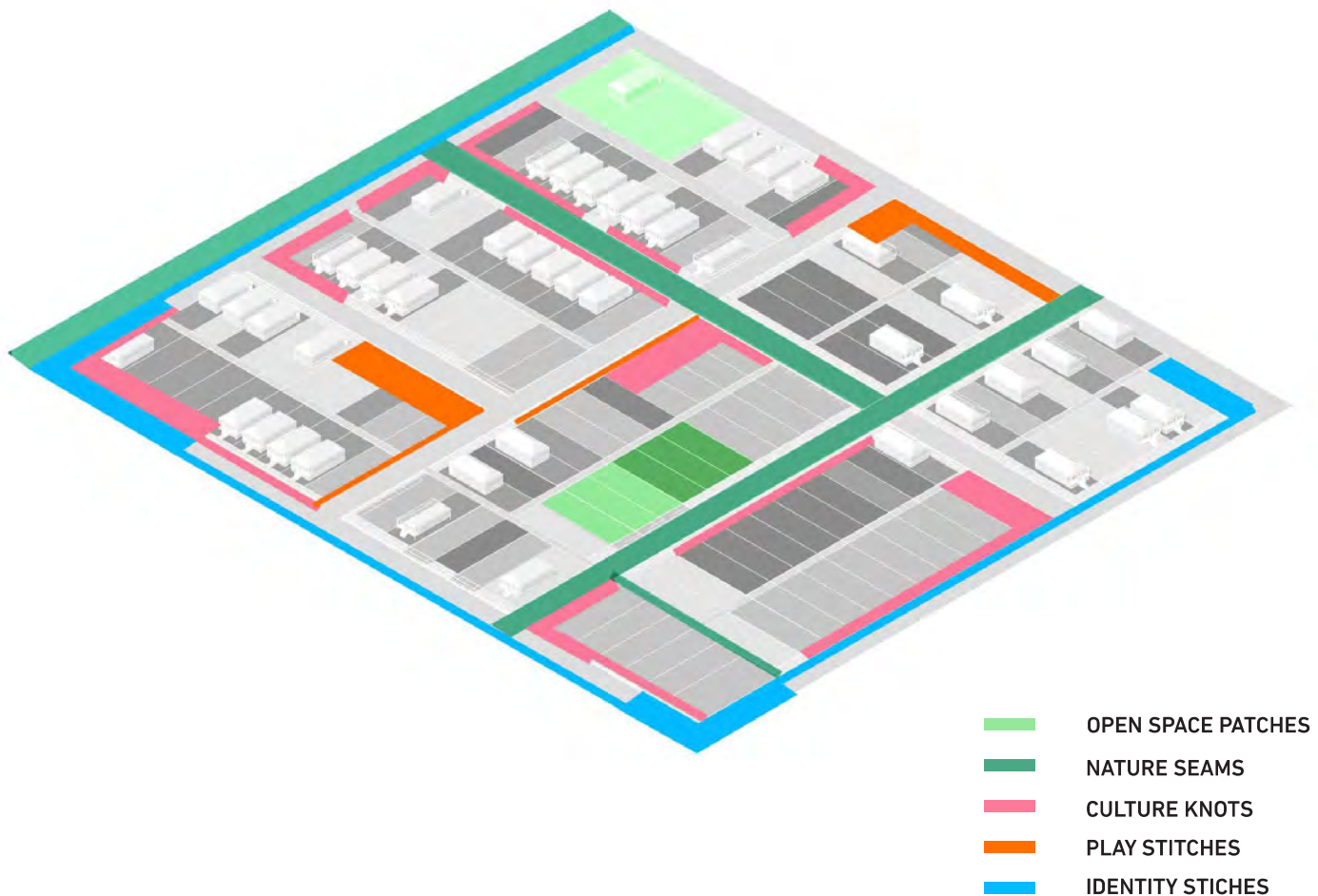

## AFTER

As the number of edge improvements grows, open vacant land will slowly begin to be redefined by the spirit and desires of the community. A unique patchwork of gardens and activated spaces will stitch the neighborhood together and create a new cultural fabric.



# Four Key Ideas

***Four dualistic themes underpin and organize the plan: nature/culture, subtraction/addition, maintenance/management and individual/collective. These themes consider ideas that are different from one another, but not oppositional. You and/or your neighbors together can choose how to balance these dualities based on the skills, time, desires and budget available.***

## NATURE / CULTURE

Activity, identity, trees, and natural areas in urban contexts are all influenced by people. East Davison Village is a tight knit community of people, neighborhood businesses, and grass-roots organizations. The neighborhood has a rich history and the collective memory of a thriving, dense and well-cared for neighborhood runs deep with residents. An active block club and dedicated community members keep that memory alive by stewarding vacant lots and investing in smart, creative entrepreneurship opportunities. Much like how people and organizations create the culture of a community, urban nature supports and organizes how members of the community enjoy and move through the neighborhood.

Throughout the neighborhood, lots that were once maintained by people are now urban nature hot-spots with increasing densities of disturbance-adapted vegetation. As the amount of vacant land expands, it becomes increasingly difficult to maintain these spaces using mowing alone, as it is time consuming and labor-intensive. Residents have the opportunity to integrate a new type of management to the community by celebrating urban nature and the value it provides, such as improving air quality, reducing the urban heat island effect and exposure to pollutants. The key to successful urban nature has to do with intentional subtraction of some existing vegetation and consistent care with the addition new plants.





## **SUBTRACTION / ADDITION**

Intentionality and care can be exhibited by subtracting or adding vegetation to your property to increase visibility, help plants thrive, and add diversity to the vegetation already there. Through subtraction, vegetation on a lot can be removed, trimmed or pruned, and mown. Through addition, vegetation can be integrated to provide shade, biodiversity, bird and pollinator habitat and beauty. Thinking strategically about how to edit the vegetation on your property is an act of design and can create different outcomes. For example, planting a boulevard may provide shade for the sidewalk, but high levels of road salt and tight growing quarters could result in increased maintenance needs. This plan will help you identify what you have on your lot and will offer suggestions for a combination of native plants and non-native, non-invasive plants that can reduce maintenance and provide a wide array of social and ecological services.

## **MAINTENANCE / MANAGEMENT**

Plants do not always behave the way people want them to! This conflict between the desired neatness of the design process and the inherent messiness of ecological process is explained below through two types of care practices. The word **maintenance** is used to describe a more active approach that preserves the integrity of a formal landscape design, while the word **management** is used to describe a less intensive approach that attempts to guide rather than control natural ecological processes. Both of these activities require lot owners to make value judgments about which plants will have access to water, light and nutrients.

## **INDIVIDUAL / COLLECTIVE**

Every new edge contributes to the collective experience and identity of East Davison Village. As different edge types collect and grow, the unique preferences of individuals will be showcased and a collective community voice will emerge.

A variety of greening and design strategies have been proposed and implemented across the City of Detroit for re-purposing vacant lots over the last decade. The edge designs in *Chapter 3: Design Typologies* address social needs by celebrating the identity and self-determination of this community. The plan intends to strengthen relationships between place and community through resident-led improvements that inspire stewardship and pride. Resident-initiated improvement activities such as clearing, caring, planting, and engaging with neighbors will help build interpersonal relationships and a sense of ownership.



# How to Use the Plan

STEP 1:

**READ** CHAPTER 2: LOT ASSESSMENT  
AND DETERMINE WHAT YOU ARE  
WORKING WITH

STEP 2:

**SELECT** DESIGNS FROM CHAPTER 3:  
DESIGN GUIDELINES

STEP 3:

**REFER** TO THE GLOSSARY FOR TIPS,  
DEFINITIONS, AND EXAMPLE IMAGES



# Where else can I learn about how to care for my lot?

## ONLINE RESOURCES

There are numerous places online to look up plant species, information about your region, as well as building tips and tricks. Websites such as YouTube can be valuable resources for how-to videos on a wide range of lot-care topics.

## TRAINING AND COMMUNITY PROGRAMS

Community education and nonprofit programs are other valuable resources for learning the skills required to build and maintain an edge design. Example garden and tree-focused organizations include Keep Growing Detroit's Garden Resource Program and Greening Detroit's "Caring for Trees" resources.

## BOOKS AND NEIGHBORS

Neighbors are a valuable resource for skill and tool sharing. Books with good pictures are a great place to get gardening ideas. Check out the gardening section of your library or ask your neighbors if they have a book you can borrow.

If you see a lot in your neighborhood that is managed in a way that you like, ask the owner to explain how he or she created it and what plants they used.





**EAST  
DAVISON  
VILLAGE**

**02**

**LOT**

**ASSESSMENT**

**TOOL**

**EDGING  
FRAMEWORK  
PLAN**

THIS PAGE IS INTENTIONALLY BLANK



# Evaluate Your Lot

Crafting a new edge from the Framework Plan first requires an assessment of the existing site conditions, materials available, costs, and time required to accomplish a design. The following pages will serve as a guide for assessing what kind of lot you might have, how to identify and work with existing vegetation, and how your edges might stitch into the larger neighborhood “quilt” of improvements.

This chapter will also guide you through the relevant planning and policy structures that are available to assist you and that might affect or limit what you can do. After completing this chapter, you will have answered the following questions to determine what kind of design suits your lot.

**What Kind of Lot Do I Have?**

**What Materials Do I Have?**

**What Do I Want to Happen in My Lot Edge?**



# Lots vs. Edges

***Edges of lots can be improved to support a variety of different types of landscapes and activities. Edge improvements can become a powerful shared neighborhood resource that are more affordable and easier to accomplish than improving an entire lot.***

**Lots** are defined by the four edges of the property that make up its boundary. Lots are standard in their dimension but vary in their character and assets. Typically lots are 30' x 100', not including the alley. The property boundary begins at the inside edge of the sidewalk. Some lots in East Davison Village have houses while some have lots of trees and vegetation. Taking stock of what is on and surrounding your lot will help shape what the land can be used for in the future.

**Land Use** is the characterization of land based on what can be built on it and what the land can be used for. Land use refers to the way that people adapt land to suit their needs, whereas zoning refers to how the government regulates the land.

**Edges** are the outermost areas on your lot. They are the boundary along the street, the alley, or the sides of your property neighboring other lots. The size and dimension you choose for an edge improvement will depend on the context of the lot, existing conditions, your budget and resources. Edges, unlike lots, are flexible in their dimensions and can range from 5' deep to 30' deep. The Edge is an opportunity to frame the rest of the lot; typically an edge will be more formal, while the rest of the lot could be formal or more naturalistic.





# “Edges” are Flexible

The “size” of your edge is flexible and is determined by you. Edges need to respect standard setbacks as outlined in the Detroit Zoning Ordinance and should be considerate of your neighbors, but are otherwise not limited by location or by how big, small, long or narrow. While some edges may be implemented in a narrow, 10-foot area along the front of your lot, others may move deeper into the site. Determining the scale of an edge improvement will depend on what already exists on the lot and what types of improvements you want to install. This diagram shows typical lot dimensions and 10’ offset lines to help you imagine how big or wide you might want to consider for your edge.

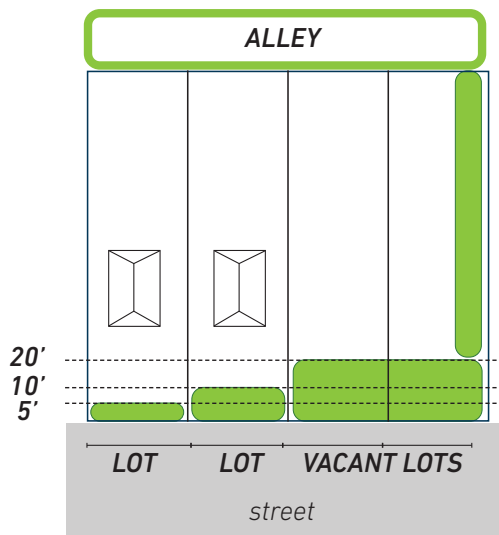

## SETBACKS

**10' or greater from the street:** Constructed elements, structures, and all garden types are allowed in this zone.

**5-10' from the street:** Mowed edges and low to medium height formal gardens are allowed in this zone.

**0-5' from the sidewalk/property line:** Mowed edges and low, formal gardens are allowed in this zone.



# Policy Decision Tree

Assuring your lot meets all local requirements is a critical step in creating an edge design. The decision tree below provides links and resources for further information on local and city processes and policies, as well as step-by-step questions to determine if you are ready to design and construct a new edge.

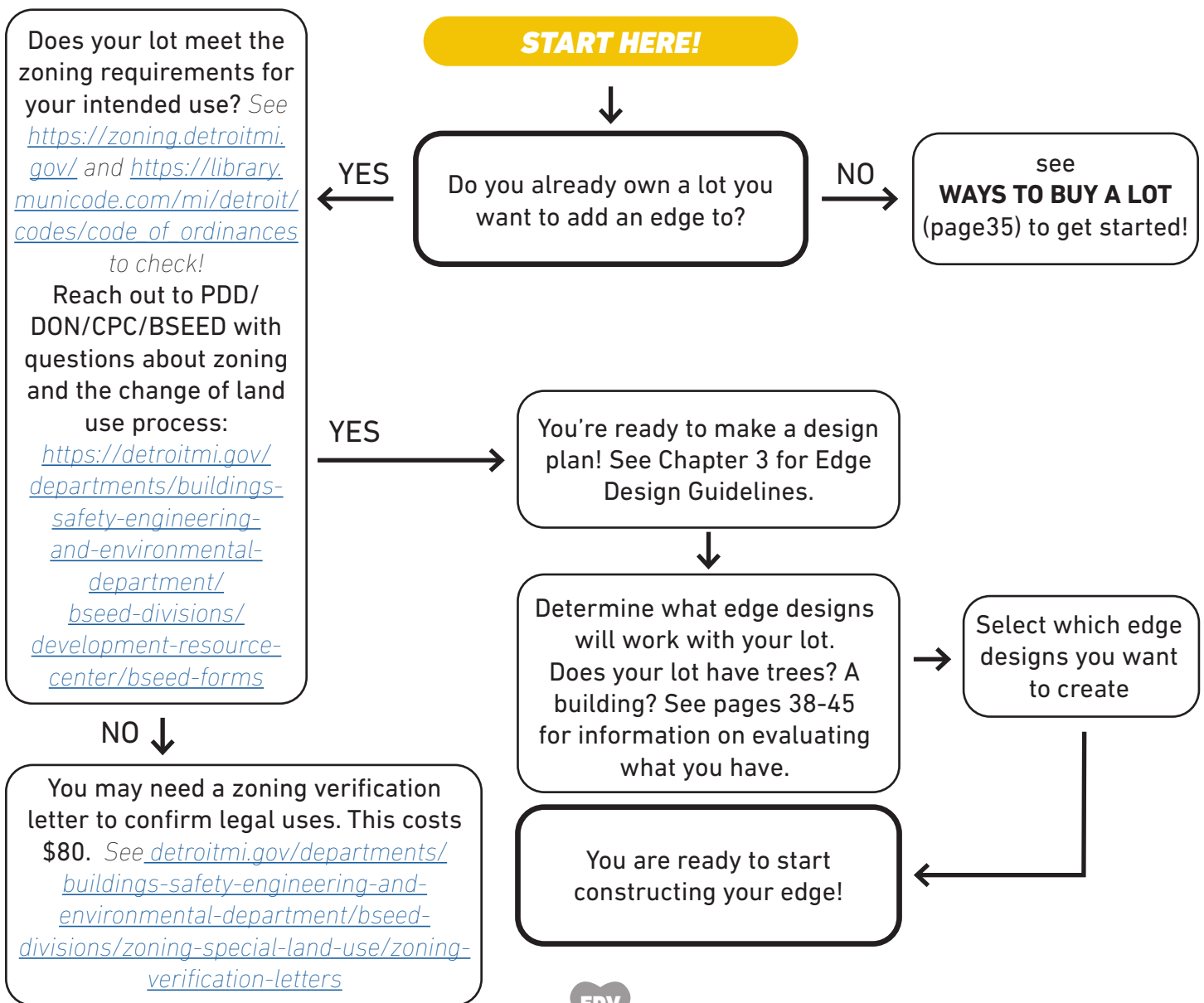

# DLBA Programs

Lot acquisition happens through the Detroit Land Bank Authority (DLBA). Below are descriptions, links and resources for the various programs available. Programs do change and evolve, so make sure to do your research to stay up to date! There are two ways to purchase land, either through “Programs” or “Projects”.

## PROGRAMS

The first place to check for information on lot programs is <https://buildingdetroit.org/land-reuse-programs/>. Here you will find the most up-to-date information on ways to purchase a lot. These programs have predetermined parameters with specific criteria for applicants, that has been established and approved by the Detroit Land Bank Authority (DLBA). For vacant lots, these programs include the Side Lot Program, Oversized Lots Program, and the Neighborhood Lot Program.

### SIDE LOT (VACANT LOTS)

- Side Lots must meet a number of eligibility criteria, including zoning, taxes, demolition clearance, size, adjacency, etc.
- Purchasers must meet several eligibility criteria including adjacency, home ownership, being current on property taxes and DLBA Compliance Achieved (if applicable)
- Lots are still \$100!

#### Sold without a Compliance requirements:

- Lots must be 7,500 square feet or less
- Now allowing land contract purchasers to participate

### OVERSIZED LOTS (VACANT LOTS)

- Oversized Lots must measure 7,501 – 15,000 square feet
- Oversized Lots will be sold for \$200, unless the value of the lot, as determined by the DLBA, exceeds \$2,500.
- Oversized Lot must be Street Adjacent to the applicant’s occupied property
- Limits sales to one per household
- Purchasers must have a Principal Residence Exemption (PRE)

Check to see if you have filed a Principal Residence Exemption (PRE): <https://www.michigan.gov/PRE>

visit [www.buildingdetroit.org](http://www.buildingdetroit.org) and [detroitmi.gov/properties](http://detroitmi.gov/properties) for detailed information on lot purchasing program updates.

## PROJECTS

Purchasers that are not eligible to purchase through Side Lot or Neighborhood Lot programs can still apply to purchase land through the Projects Program. Properties are priced using fair market value. Some projects may be eligible for a discount. Applicants will use the online Properties Application Form to initiate this sale process ([buildingdetroit.org/development-projects/](http://buildingdetroit.org/development-projects/)). Additional application materials may be requested, including a Plot plan for land-based projects. Land sales are subject to a development agreement and will be reviewed by City staff and approved by the DLBA Board. All sales over 9 parcels will require additional approval by City Council.

### NEIGHBORHOOD LOTS (VACANT LOTS)

- Allows homeowners to purchase lots within 500 feet of their primary residence
- Purchasers must have a Principal Residence Exemption
- Sales limited to two per household
- Sales will have a three-year Compliance period, allowing the DLBA to reconvey the lot if the purchaser is found to be at fault for blight violations
- Requires the endorsement of the local (or at-large) City Council Member, Block Club registered with the Department of Neighborhoods, DLBA Community Partner in good standing, or Department of Neighborhood District Manager or Deputy District Manager.
- See [buildingdetroit.org/sidelots/index/neighborhood](http://buildingdetroit.org/sidelots/index/neighborhood) for more information on the Neighborhood Lot Program

### HOMESTEAD LOTS (LOTS + HOUSES)

DLBA will select bundles of vacant lots to be sold alongside certain homes via Own It Now, Auction, and Rehabbed & Ready listings. The lot must be either:

- Adjacent to a DLBA-owned residential property that includes an existing residential structure of 1-4 units, or
- part of a contiguous assemblage of Homestead Lots that are Adjacent to such a property
- If a purchaser defaults on Compliance terms of the house, DLBA will have the right to take back title to Homestead Lots
- Lots sold for \$100 each, in addition to the sales price of the bundled property.



# Ecological Context

East Davison Village is located in the Eastern Temperate Forest region of the United States. This region's vegetation is defined by the amount of rainfall, the temperatures throughout the year, the soils, and other conditions. Landscapes, if left untouched, in most cases will return to a forest. Maintenance and management is what prevents your lot from returning to its natural state.



Image: EPA.GOV

■ EASTERN TEMPERATE FOREST

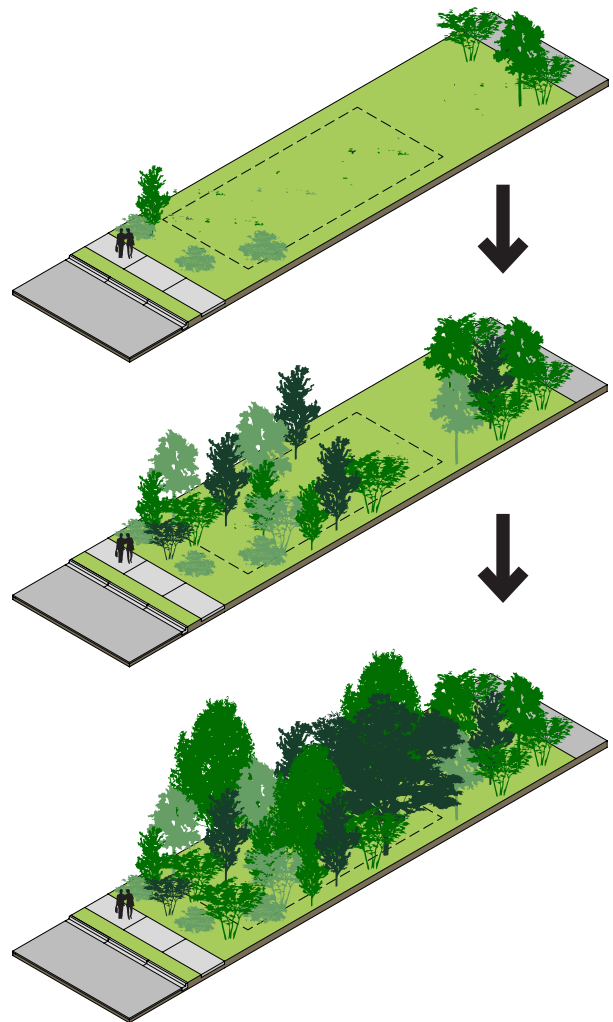

CHANGE OVER TIME IF UNMAINTAINED



# Assessing Trees

## TREES AND THE CITY

Trees are a valuable asset to neighborhoods. Trees provide shade, they can lower temperatures in the warm months, and add visual interest year-round. Trees throughout a city also provide food and habitat to migrating birds and other animals.

## TREES AND YOUR LOT

Adding trees to individual lots is what builds the community of trees city-wide that, all together, can lower city temperatures, provide regional habitat, and provide ecological benefits. Trees, when properly maintained, can also add significant beauty as well as financial value to a property. Trees are relatively low maintenance after the first two years, making them a long-term investment in the beauty and success of a landscape. Trees should not be planted within the 10' required setback zone shown below. Trees may be planted in the boulevard zone but risk being removed for utility updates.

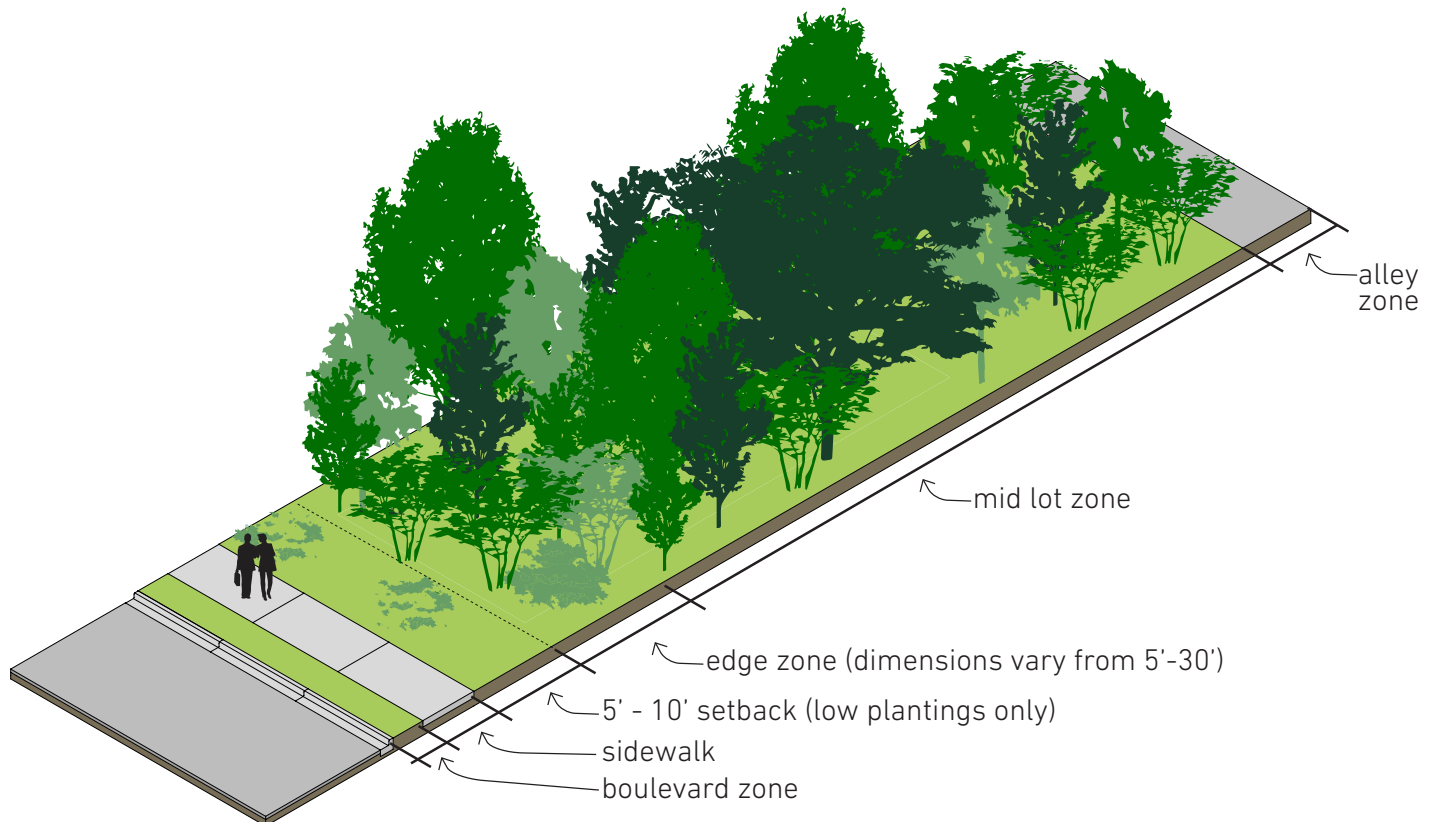

# Assessing Trees

## IDENTIFYING TREES TO KEEP

Determining what trees on your lot to keep requires first assessing their overall health. Healthy trees typically have one trunk (not multiple), are full in shape and leaf volume, do not have dead branches projecting from the top of the tree, and display healthy green leaves. Determining which trees to keep also requires considering the diversity of trees in the community. Currently, trees such as Norway maple, green ash, and silver maple make up 60% of trees in Detroit. Favoring trees other than these will increase diversity, and in turn, the ecological health, of the city.

## IDENTIFYING TREES TO REMOVE

Signs of an unhealthy tree include broken branches, a large amount of dead branches with no leaves that snap easily, wilting, cracks and holes in trunks or limbs, leaf-free branches, abnormal leaf color, visible insects or insect evidence, disease evidence and fungus growth. Unhealthy trees and dead trees should be removed so avoid any damage to people or properties they may create if they were to lose branches or fall down. Tree removal is expensive, so working together with your neighbors to identify multiple trees for removal can be a way to minimize costs and remove trees across larger areas more easily (refer to the Asset Map at the end of this chapter for neighbors that can help!). Similarly, just because a tree is on the list below doesn't mean it isn't providing ecological function if it is in a healthy condition.

LATIN NAME	COMMON NAME	NOTES
<i>Acer campestre</i>	Hedge Maple	Weedy species
<i>Acer negundo</i>	Box Elder	Weak wooded and weedy
<i>Ailanthus altissima</i>	Tree of Heaven	Root suckering and weedy
<i>Fraxinus americana</i>	American Ash	Emerald Ash Borer (EAB) problem
<i>Fraxinus nigra</i>	Black Ash	EAB problem
<i>Fraxinus pennsylvanica</i>	Green Ash	EAB problem
<i>Maclura pomifera</i>	Osage Orange	Root suckering and weedy
<i>Morus alba</i>	Common Mulberry	Weedy species
<i>Paulownia tomentosa</i>	Princess Tree	Root suckering and weedy
<i>Phellodendron amurense</i>	Amur Cork Tree	Weedy species
<i>Pinus nigra</i>	Austrian Pine	Disease problems
<i>Platanus occidentalis</i>	American Sycamore	Disease problems
<i>Populus alba</i>	White Poplar	Weak wooded
<i>Populus tremuloides</i>	Quaking Aspen	Root suckering & thicket forming
<i>Pyrus calleryana</i>	Callery Pear	Seedling are weedy & root suckering
<i>Robinia pseudoacacia</i>	Black Locust	Root suckering and weedy
<i>Salix x sepulcralis</i>	Weeping Willow	Weak Wooded
<i>Sorbus acuparia</i>	European Mountain Ash	Weedy & disease susceptible
<i>Ulmus americana</i> seedlings	American Elm	Seedlings get Dutch elm disease



**Healthy specimen tree**



**Healthy tree edge**



**Healthy diverse stand of trees**



**Dead and broken tree branches**



**Peeling bark**



**Dead branches at the top**



**Discolored leaves (oak wilt)**



**Leaf galls**

Visit [greeningofdetroit.com/caring-for-trees](https://greeningofdetroit.com/caring-for-trees) for a list of prohibited trees in Detroit and more information on buying new trees



# ***Assessing Vegetation***

## **IDENTIFYING PROBLEM PLANTS**

As discussed in chapter one, some plants need to be removed from your lot to help it succeed. Problem plants include those such as poison ivy or aggressive vines. Using gloves and wearing long sleeves will prevent skin irritation when removing toxic plants. Vines that are climbing utilities should not be touched. The city should be contacted about removing anything that could be dangerous for lot owners to interact with.

## **CARING FOR EXISTING PLANTS**

After determining what plants on your lot are worth keeping, the next step is to determine how to help them thrive. Regular watering and pruning may be required for some, while others may need more room to spread out which requires removing other trees and shrubs that might be competing with it. The first step in determining what to keep is considering what you want the end product to look like. Selecting trees that look healthy and have room to grow freely will produce the best outcomes overall.

## **EVALUATING GROWING CONDITIONS**

An essential step in determining what will happen on your property is understanding the growing conditions of your lot. When purchasing plants, look for labels that signify their sun needs to ensure the best fit for your edge conditions.

### **SUN/SHADE**

Some plants do better in shade than others. Before selecting a plant for your lot, it is important to research what its needs are for sun and shade. Plants that need full sun require direct sun for six or more hours per day. Plants in need of partial shade need two hours of direct sun each day or shade for at half the day. Finally, plants that need full shade conditions require an hour or less of sun every day. Plants under a tree canopy are often full-shade. Observe your edge throughout the day to get a sense of how much sun it gets before selecting plants.

### **DRAINAGE**

Observe your property after it has rained to determine where water collects on your lot. Take note of how long the water stays for. Avoid planting in these areas unless you plant species that like “wet feet” or, are tolerant to being in standing water for short periods of time. See page 76 for more information on rain gardens.

**SEE CHAPTER 3: DESIGN GUIDELINES FOR FURTHER INFORMATION ON SUBTRACTING, CARING FOR, AND ADDING PLANTS AND RECOMMENDED PLANT LISTS!**





**VINES**



**Celastrus orbiculatus (Bittersweet)**



**Vitis Riparia (Riverbank grape)**

**TOXIC AND HAZARD PLANTS**



**Toxicodendron radicans (Poison ivy)**



**Pastinaca sativa (Wild parsnip)**



**Conium maculatum (Poison hemlock)**

**PLANTS THAT INDICATE NEGLECT**



**Ailanthus (Tree of Heaven)**



**Populus deltoides (Eastern Cottonwood)**

Visit [greeningofdetroit.com/caring-for-trees](https://greeningofdetroit.com/caring-for-trees) for a list of prohibited trees in Detroit



# Management / Maintenance

***Maintenance and management go hand-in-hand. By removing problem plants, cultivating existing plants, and adding new plants, you can minimize maintenance efforts and create landscapes with high ecological function.***

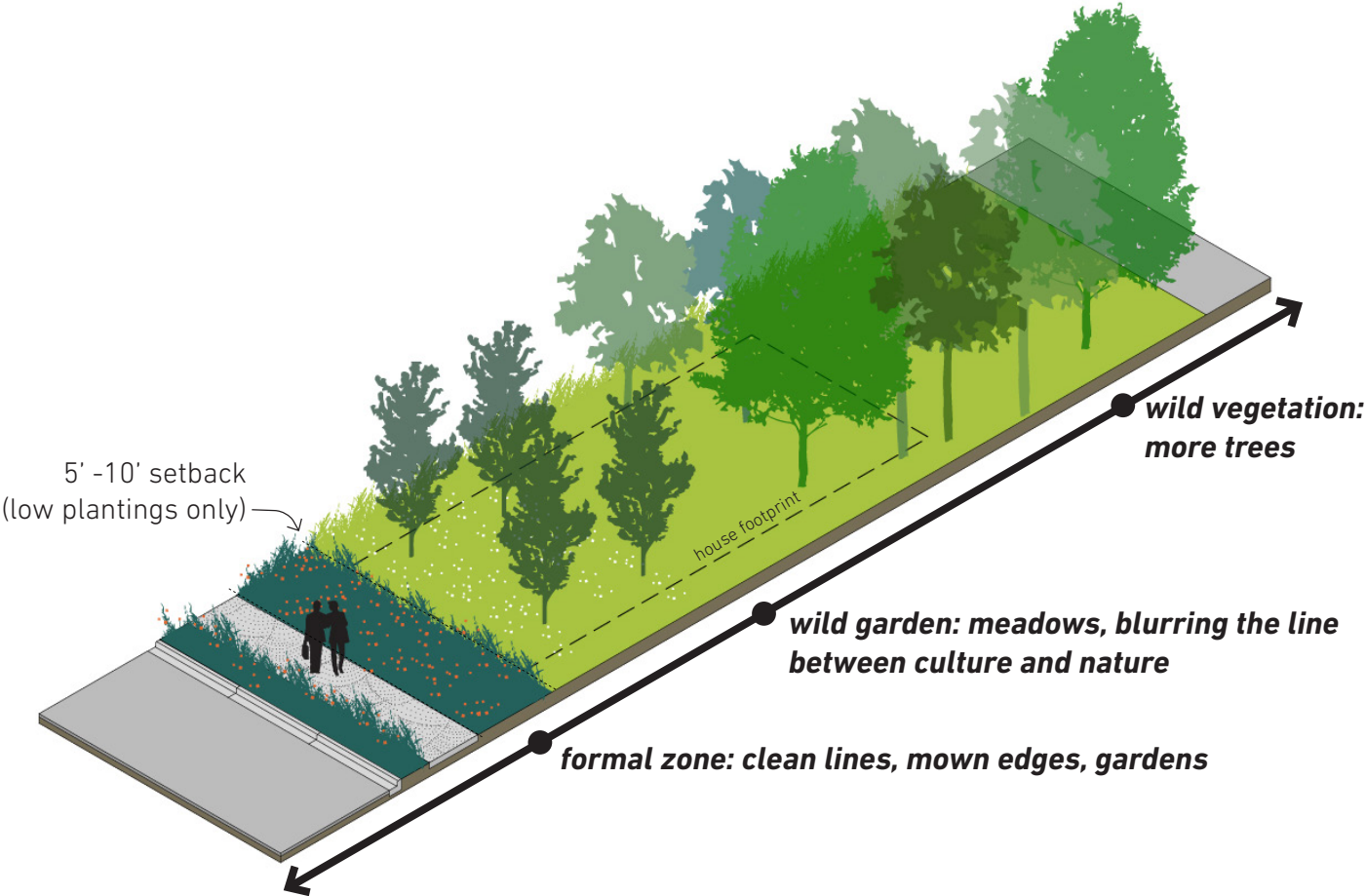

## **MANAGEMENT STRATEGIES**

Management directs and shapes the natural ecological processes already happening on your lot. Determining how to manage your lot requires deciding which vegetation you want to remove and which you want to help thrive. For example, managing a lot can make it less dense and increase visibility into the lot. Managing your lot involves employing different strategies depending on the conditions of your lot. Determining how you will manage your lot requires deciding how much time you want to put into it and what resources you have available to you.

### **TIME**

Picking a management strategy requires assessing the amount of time you prefer to spend managing your lot. Managing vegetation requires varying time commitments depending on your management goals. The results of effective management strategies can take time, and sometimes are not apparent right away.

### **RESOURCES, COLLABORATION AND PARTNERSHIPS**

Working with neighbors is a great way to learn new management skills and techniques. Neighbors can share knowledge, tools, and expertise on managing lots with one another.

## **MAINTENANCE METHODS**

Maintenance focuses on the upkeep of your lot. Unlike management, maintenance is about the upkeep of more formal landscapes and other intentionally designed spaces. Maintenance processes will be specific to the type of edge you decide to install. See Chapter 3: Edge Design Guidelines for more detailed maintenance information for each edge!

### **MOWING**

Mowing techniques and timing will depend on your mowing goals. Depending on the time of year, mowing can occur about once a week. Grass should not be mowed when wet. Creatively mowed spaces can be changed by letting the grass grow back in to create a blank slate and testing something new!

### **PRUNING/CLEARING/CUTTING**

Plants that are showing signs of disease or have dead branches or stems should be pruned. Trees should be pruned in the winter. Shrubs and other plants can be pruned at any time of year. See the glossary for more information about pruning techniques.



# What edge type do I have?

***What assets does my lot have? Determining the assets and constraints of your lot will inform the future of the edge. Edges can be improved along the street edge, alley edge, or long edge of your property.***

## ***STREET EDGES***

Street edges are those that are along the street-side of your lot. Edges along the street come in a number of conditions, described in the following pages. Remember your property begins at the inside edge of the sidewalk. These edges can be enjoyed by pedestrians as well as people driving or biking through the neighborhood.

edge facing the street  
(depth of edge varies, 5'  
min - 30' max)

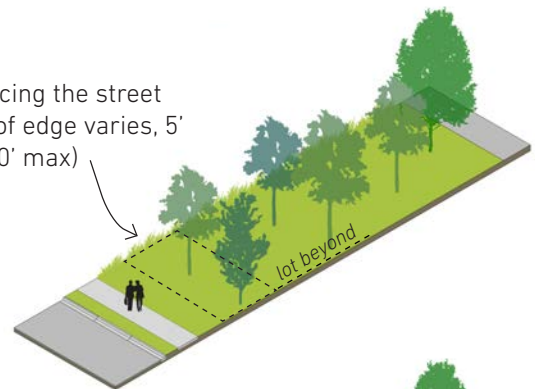

## ***ALLEY EDGES***

Alleys have become increasingly overgrown, impassable and difficult to maintain. Do you have an alley connected to your lot? How could you increase visibility and access through the neighborhood by clearing it out? If dumping is an issue in your alley, consider edge typologies that double as dumping-prevention strategies.

edge facing/  
including the  
alley



## ***LONG EDGES***

Long edges are those that run the length of the lot from street to alley. These edges could be on a corner or mid-block. These edges can connect street edges to the alley to create dynamic inter-neighborhood connections.

edge along  
the sides of  
a lot

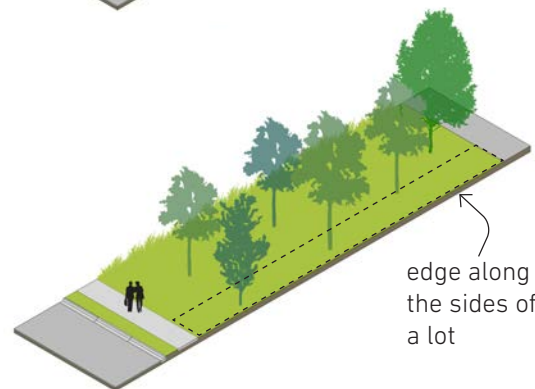

# What edge context do I have?

***Determining the context of your lot will help you decide what to put on it! Corner lots have high visibility and good access. Midblock lots will be quieter and enclosed feeling.***

## **Midblock Lot**

Midblock lots are protected from the increased traffic at intersections and can feel safer for improvements geared towards play and uses for children. Midblock lots also can provide good places for connections through a block to an alley or other lots beyond.

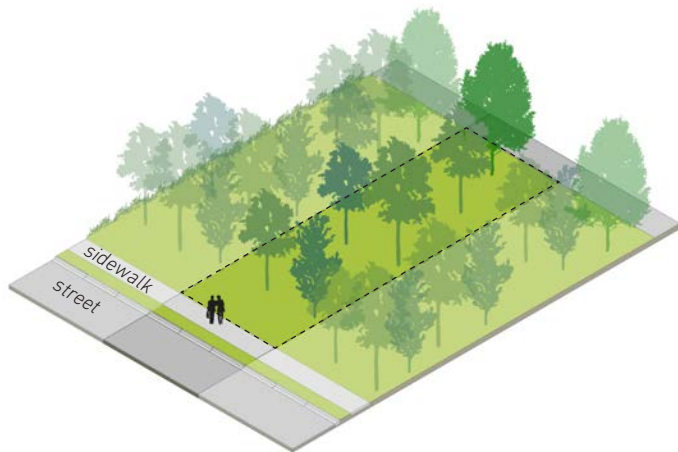

## **Corner Lot:**

Corner lots have a high level of visibility and access. These lots are great for play and gather spaces as well as exchange spaces. Corner lots are also great candidates for identity elements, as they can be seen from many directions and serve as wayfinding.

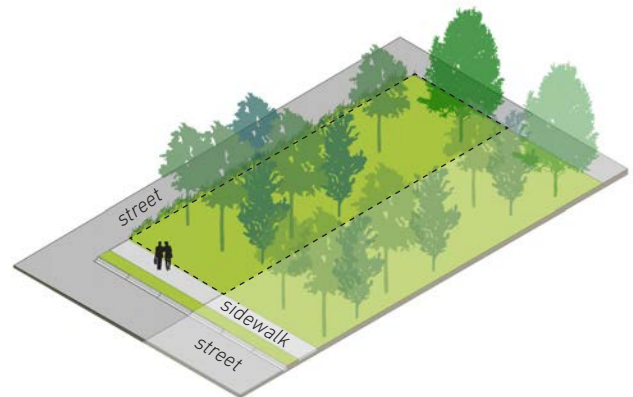

# What is the condition of my edge?

**Every lot has a unique set of assets and challenges. Some lots will have curbs, streets, and sidewalks while others may have overgrown vegetation, partial to no sidewalk, and no curb.**

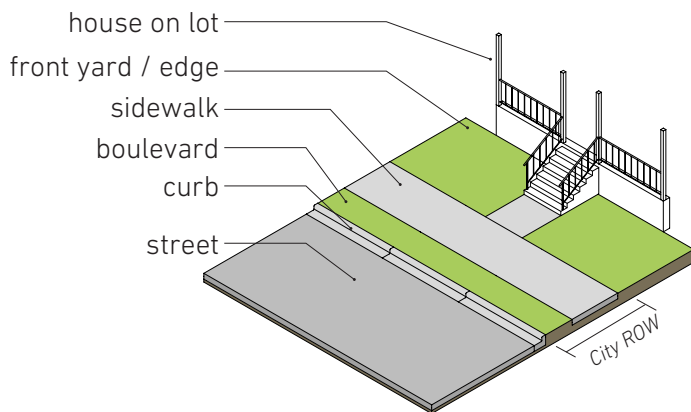

## 1 / ORIGINAL CONDITION

Original condition lots have an intact curb, boulevard, sidewalk, as well as a home. These lots have space for edge installations in the boulevard and the front yard.

It is important to take note of the city "Right Of Way" (ROW) on each lot. The city ROW is space that is used for the public and utilities. It is maintained by the City. Any designs here could be damaged or disrupted by maintenance.

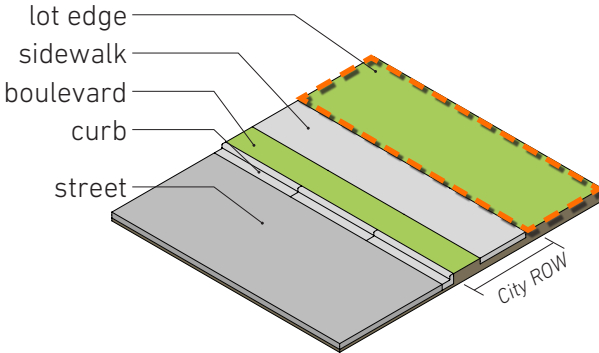

## 2 / INTACT STREET EDGE

The intact street edge condition has an intact curb, as well as sidewalk, but no structure on the lot. These lots offer connection to surrounding sidewalks and offer lots of flexibility for edge installations.

**Boulevards are a 'build at your own risk' zone!** If the City needs to place utilities in the boulevard zone your edge design will not be replaced after.



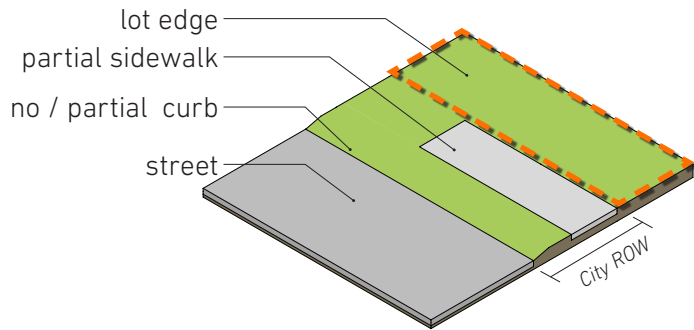

### 3 / INCOMPLETE STREET

The incomplete street condition lacks a curb and/or a complete sidewalk. These lots have flexible space to work with when creating a new edge.

Even when there is no sidewalk there is still a ROW to consider! Make sure to start your edge designs on the lot side of where the sidewalk would be to avoid disruptions from utility maintenance.

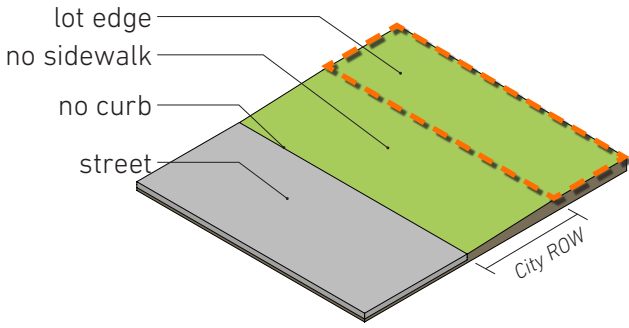

### 4 / BLANK CANVAS

Blank canvas lots are those that have no sidewalk, curb, or structure. These lots are wide open and have the potential to accommodate any edge type. As above, it is important to measure where the sidewalk would be and work from there to avoid damage to your edges.

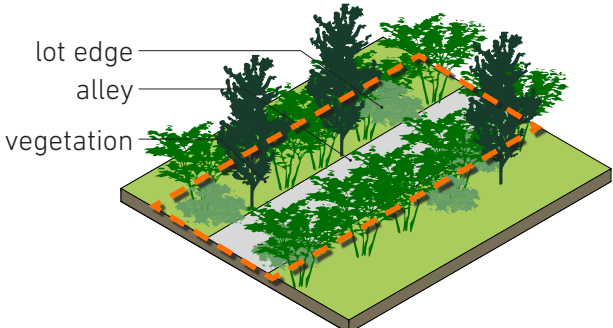

### 5 / ALLEY

Alleys come in many conditions. Many alleys are overgrown with vegetation and have high potential to be managed and maintained to increase visibility and passing space.



**Example of Original Condition**



**Example of Incomplete Street**



**Example of Alley Vegetation**



# What do I want to accomplish?

***Asking the following questions will help determine which edge typology or design improvement to choose.***

## ***DO I WANT TO MAKE A PLACE TO SIT?***

Places to sit will be edges where community members gather. These places are where people might stop to take a rest or enjoy the weather.

## ***SHOULD IT BE A PLACE TO PLAY?***

Play edges are places kids will gather. Places to play are active spaces where noise and activity could be frequent.

## ***DO I MIND DOING MAINTENANCE?***

Each edge design will require a different level of maintenance. Constructed elements such as benches will require occasional painting and repairs. Plant s and gardens will need pruning, weeding, and ongoing care.

## ***WHAT DO I WANT PEOPLE TO DO HERE?***

Consider what you want visitors to your lot to do when engaging with an edge. If you want community members to have a place to sit and talk, the GATHER edge could be a good choice. If you want to create a place for performances, the EXCHANGE edge would be a good fit. If you want a more passive edge, consider IDENTITY and NATURE typologies.

## ***HOW DO PEOPLE GET HERE?***

Is your lot near other existing edge installations? Is there a sidewalk along your lot? Assessing ease of access to your lot may inform what you put there as well. If your lot is on a corner with good access, intact sidewalks, and high visibility it could be a good place for community memers to gather.

## ***WILL IT BE A GARDEN?***

Gardens are a great way to beautify, frame, and screen your lot. These techniques prevent dumping if planted more densely as a buffer and add beauty to the neighborhood. Gardens require maintenance, especially during the spring and summer months. These designs fall into the NATURE typology







## NATURE

Lots that focus on caring for nature are ones that emphasize the ecological value of the plants and trees on the lot.



## PLAY

Play edges are places where kids can gather to run, jump, skip, and balance.



## IDENTITY

Identity edges celebrate the culture of East Davison Village. They are places for welcoming community members and visitors to the neighborhood.



## GATHER

Gather edges are places to sit and rest, have a conversation, or enjoy the sights of the neighborhood.



## GROUND

Ground edges are the connectors. They are paths that connect one sidewalk to another. When links get wider, they become places to gather on. Links can be mowed, crushed stone, or even pavers.



## EXCHANGE

Exchange edges are places to share ideas, to perform a poem or give a presentation. They encourage gathering around in conversation, sharing ideas, and celebrating community.



# What resources do I have?

***Deciding which design is best suited for your edge involves a careful consideration of the cost and effort associated with each. Sharing resources, costs, skills, tools, and time with neighbors could help grow the quilt faster and more easily.***

## **COST**

Edge installations can range from the low-end (approximately \$200) to the high-end (approximately \$5,000). Materials such as lumber and trees are more expensive than plants, for example. Cost will undoubtedly be one of the first considerations when determining which edge type you (or a group of community members collaborating together) are able to implement.

Keep your eye out for grants, new programs and opportunities through the City of Detroit, Detroit Future City and other organizations that aim to accelerate vacant land revitalization in Detroit. Check in with the East Davison Village Community Group members and your neighbors to see whether they know of grant opportunities to help fund the improvements you want to make.

Materials such as stencils, paint, brushes, leftover lumber, and mulch can be shared with neighbors to extend edge lots further across the neighborhood.

## **LABOR**

Another important factor in determining which edge typology or improvements to make is how much effort you want to put into the construction and maintenance of any installation.

Utilize the asset list (on the facing page) to find community members with the tools and skills you need to support you. Keep investment for improvements as local as possible to support your community and help expand experience and skills within the community to build the quilt.

Check in with East Davison Village Community Group members to see whether there are opportunities to host or participate in workshops and demonstrations that can help you teach or learn the skills needed to construct different edge typologies.

Consider communal building or site preparation days to construct multiple edge improvements at once. Sharing time, labor and resources will keep costs down.



# What resources do we have as a community?

NAME	COMPANY	CONTACT	SKILLS	TOOLS
Mark	His Management, LLC	313-523-5595	lawn care, gardening, carpentry, small construction, snow removal, leaf pick up	riding and walk behind mowers, leaf blowers, powertools and saws, snow clearing tools
Dwayne	His Management, LLC	586-690-2645		
Carrie Morris	CMAP	carrie@carriemorris.com	lead workshops on setting up a garden, can be contracted to build a garden	
Monty Etcorn	CMAP	montyetcorn@gmail.com		
Derrick Sturgis		313-467-9781	draft drawing	lawnmower, handtools
Mr. Berry		734-833-7786	licensed contractor	
Morris Chappelle		313-465-2845	construction	

If you would like to be added to a list of community resources contact the East Davison Village Community Group.



# Edges in Context

When assessing your lot, consider the Stewardship Map and the Edging Framework Plan Quilt (*see Chapter 1: Introduction*) to see what opportunities exist for you to connect your property to existing assets and places of promise. Another resource is to review the Campau/Davison/Banglatown Neighborhood Framework Plan to understand how your neighborhood is being planned to grow over time. All of these maps and plans have been drawn and developed with guidance and direction from East Davison Village community members.

As edges stitch together to create a quilt of improvements that benefit everyone in the neighborhood, it is important to consider that changes to your lot could also negatively impact your neighbors. The following questions will help determine the potential impact your lot improvements could have on neighbors:

1. Is this a place that will host large groups?
2. Will I be increasing or decreasing visibility in my lot?
3. Does the edge I want to improve touch my neighbors lot?
4. Does my neighbor have any needs, concerns or ideas that could make my ideas better or easier to implement?

see

[detroitmi.gov/campaubanglatown](https://detroitmi.gov/campaubanglatown)

to see the Campau/Davison/Banglatown  
Neighborhood Framework Plan



# Making the Quilt

***Each edge in the community becomes another stitch pulling the neighborhood together. As the number of edge improvements increase over time, East Davison Village becomes more connected, more stable, and more beautiful.***





**EAST  
DAVISON  
VILLAGE**

**03**

# **EDGE DESIGN**

**GUIDELINES**

**EDGING  
FRAMEWORK  
PLAN**





# Why Edges?

The East Davison Village Edging and Framework Plan is based on the 2019 Campau/Davison/Banglatown Neighborhood Framework Plan. These design guidelines are the next step in implementing the vision of the Neighborhood Framework Plan at a detailed level. While the Neighborhood Framework Plan offered a high-level vision of the future of the community, the Edging and Framework plan offers guidance on edge-scale changes to your lot, including the detailed construction diagrams and alternatives found in this chapter.

Once you have assessed your lot using Chapter 2: Lot Assessment, it is time to decide how you want to alter it. Edge typologies are ways of transforming the edge of your lot to create beautiful, safe, and well-cared for spaces. There are six types of edges: **Garden, Ground, Identity, Play, Gather, and Exchange**. The strategies for these six typologies can be mixed and matched to create simple, single-lot spaces or expansive multi-lot edge networks. Simpler designs in the Garden, Ground, or Identity sections will require less time, money and people to execute. More elaborate designed spaces in the Play, Gather, or Exchange sections will need more resources and planning to ensure they can be built. When deciding where to start several factors should be considered:

**DESIGN** | Adding designed elements to your lot might include a bench or sign, or maybe creating a space to gather or play. **Different additions to your lot require a range of effort and cost.** Consider both what you want to accomplish with your lot edge and what is reasonable for you to accomplish.

**RESOURCES + COST** | Each typology explains the materials, labor and cost associated with the execution of the design. Choose a typology that is feasible for you to install and ask you neighbors for help if you need it!

**MAINTENANCE + CARE** | Maintenance effort and time can range from **minimal** (requiring little effort) to **intensive**: requiring a lot of time and effort to keep up. This range of maintenance effort, from low to high, is a critical aspect to determining what to put on an edge.



# DECISION SPECTRUM

The design decision spectrum considers a range of effort from simple (elevate it) to more complex (activate it). While there are many variations that can be created depending on your interests, resources, and time, there are six primary typologies that can be created along this spectrum: **1) Garden 2) Ground, 3) Identity, 4) Play, 5) Gather, and 6) Exchange**. Within these six typologies there are also a range of construction options and the possibility to mix and match multiple typologies depending on your resources and lots available. These two spectrums will help you to decide where you fit within them and which typology works best for you.

**maintenance + care** Maintenance effort and time can range from low-effort and easy to requiring a lot of time and effort to keep up. This range of maintenance effort, from low to high, is a critical aspect to determining what to put on an edge.

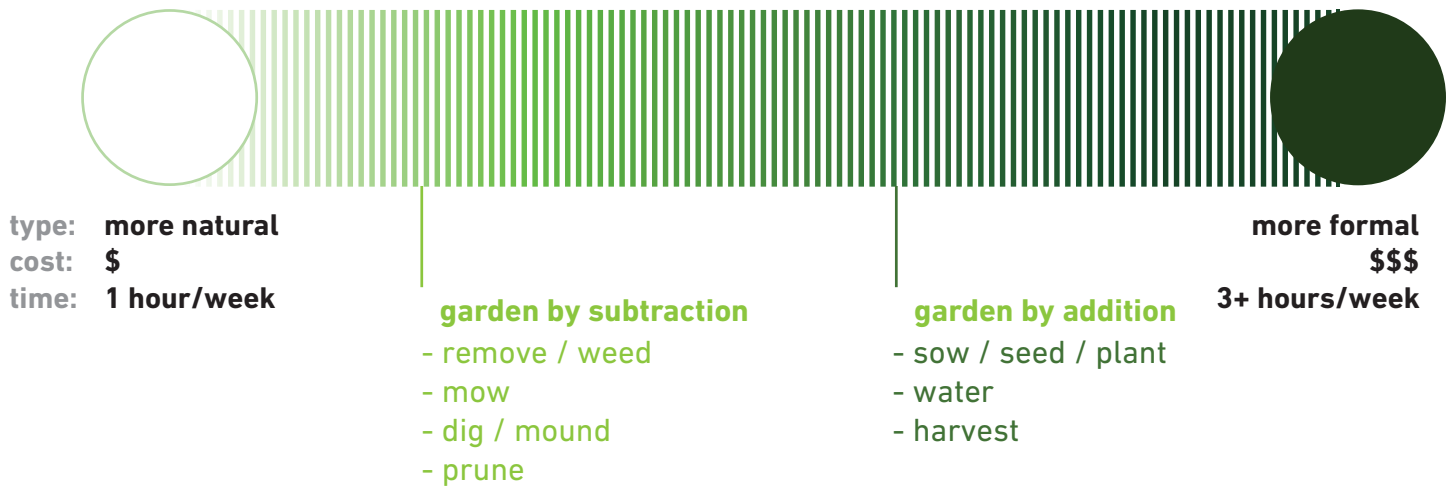

**design** The design spectrum considers a range of effort from simple (elevate it) to more complex (activate it). While there are many variations that can be created depending on your interests, resources, and time, the six typologies generally fall across the spectrum as easier achieve (ground + identity) to more complex to construct (play, gather, + exchange).

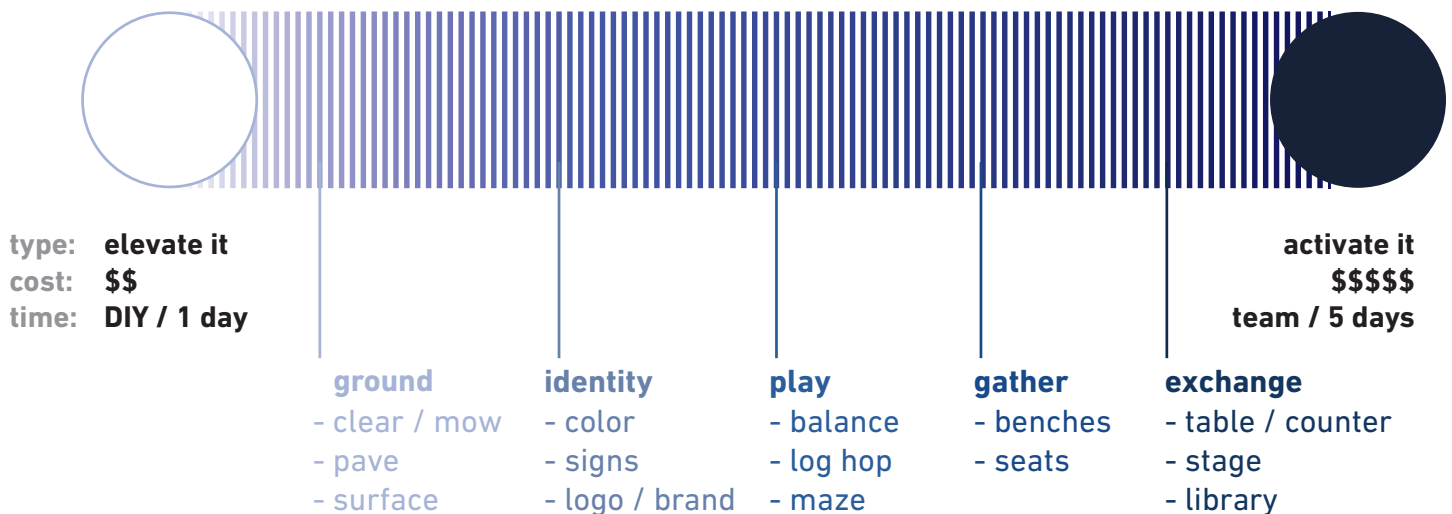

# EDGE TYPE MATRIX

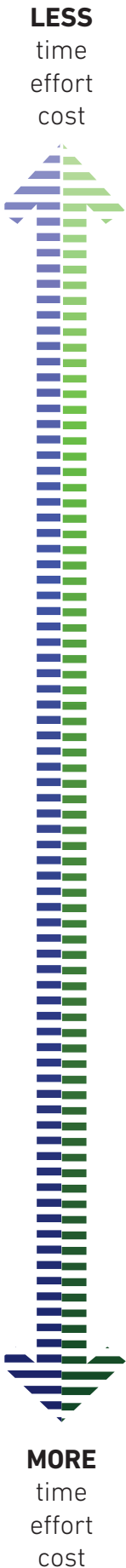

## 1. GARDEN

- + Garden by Subtraction
- + Garden by Addition



## 2. GROUND

- + Mown
- + Crushed Stone
- + Stone Steppers



## 3. IDENTITY

- + Welcome Beacons
- + Color Block Planting
- + Stencil



## 4. PLAY

- + Timber Time
- + Log Hop
- + Play Mounds



## 5. GATHER

- + Small Gather
- + Medium Gather
- + Large Gather



## 6. EXCHANGE

- + Community Table
- + Community Stage
- + Market Stall



# Before You Start

Before you begin the process of changing your lot, it is important to understand the existing conditions of your property and the impacts any improvements might have on your neighbors.

## TEST BEFORE YOU DIG

It is important to understand what types of soils you have on your property and determine whether there are any contaminants present before you dig.

Online resources to help you assess and test your soil can be found here: [https://www.michigan.gov/documents/mdard/Working\\_With\\_Soil\\_in\\_Urban\\_Areas\\_452152\\_7.pdf](https://www.michigan.gov/documents/mdard/Working_With_Soil_in_Urban_Areas_452152_7.pdf)

## CALL BEFORE YOU DIG

Locate underground utilities before beginning your lot design. MISS DIG provides a free service to Michigan residents by locating and marking utilities on requested properties. Call (800) 482-7171 or 811 at least three days before you plan to start digging on your lot.

More information can be found at: <https://www.missdig.org>.

## TALK TO NEIGHBORS

Discuss lot changes that could impact your neighbors with your neighbors! The following questions will help determine the potential impact your edge changes will have on neighbors:

1. Is this a place that will host large groups?
2. Will I be increasing or decreasing visibility in my lot?
3. Does my edge design run between our homes/lots?
4. How will I make it clear where my lot ends and my neighbor's lot begins?



## BRANDING + MATERIALS

Consistent branding and materials used throughout the neighborhood communicate intentionality and care along the lot edge. The colors, logo, and materials were all vetted through the community as representative of the vibrant character of East Davison Village. The elements can be found throughout the six edge typologies, tying them all together throughout the neighborhood.

### BRANDING



*CUSTOM STENCILS*



*COLOR PALETTE*

Identifiable colors and logo give the neighborhood a sense of identity and can communicate or mark the extent of the neighborhood. The colors and logo can be painted on the furniture and elements detailed in this chapter.

### MATERIAL FAMILY



*DOUGLAS FIR BOARDS*



*DOUGLAS FIR SQUARE TIMBERS*



*CUT LOGS*



*WOOD PALLETTE*

Simple and standardized materials make the construction of furniture relatively easy and accessible to the community and keep construction costs down.



## SINGLE LOT OPPORTUNITIES

*POSSIBLE DLBA LOT PROGRAM MATCHES:*

*Side Lot | Accessory Structure Lot | Neighborhood Lot*

A single is an opportunity to plant a garden, manage existing vegetation, build a bench, or introduce identity. Even if you have a house on your lot, the edge is a perfect place to create or more inviting and safe edge by establish plants and identity.

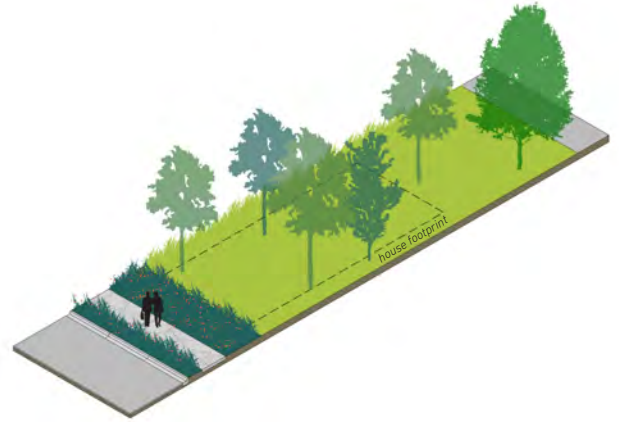

## LINKED LOTS OPPORTUNITIES

*POSSIBLE DLBA LOT PROGRAM MATCHES:*

*Side Lots | Oversized Lots | Homestead Lots*

Two adjacent lots are an opportunity to expand the edge to create spaces to Gather or Play. Garden, Ground, and Identity work well in combinations to create a more holistic edge.



## MULTI-LOT OPPORTUNITIES

*POSSIBLE DLBA LOT PROGRAM MATCHES:*

*Oversized Lots | Homestead Lots*

Multiple lots can allow all of the typologies to activate the edge. If you only have one lot, collaborate with your neighbors to create linked edges that span multiple lots! Garden, Identity, Gather, and Exchange are great for multi-lot opportunities. The quilt of edges becomes more effective when many lots work together.

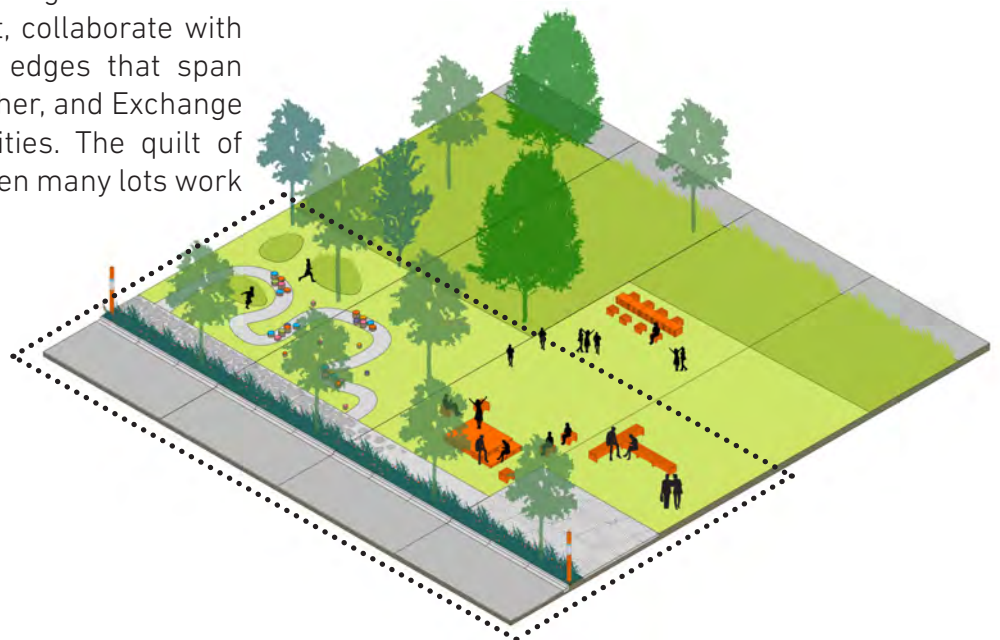

see **page 35** in  
**Chapter 2: Lot  
Assessment Tool** for  
detailed information  
on lot programs



# EDGES CAN BE MIXED AND MATCHED, COMBINED AND CHANGED OVER TIME

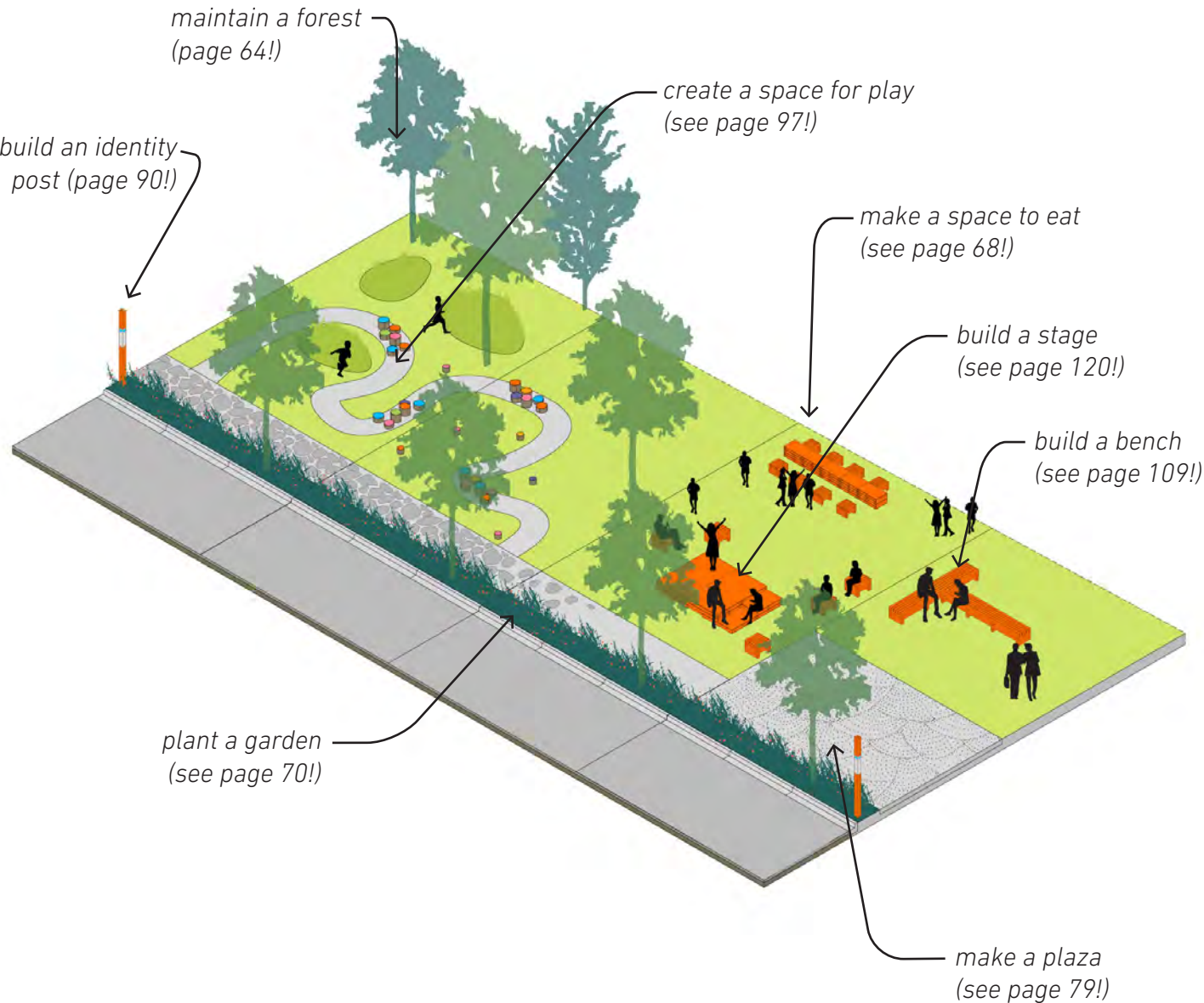

# GARDEN

**GARDEN** encompasses the existing vegetation and new plants added to the edge. The simplest way to transform an edge is through the Garden. Overgrown lots have the potential to be made more beautiful and safe through the subtraction and addition of plants. This section will tell you how to:

- + *manage existing plants*
- + *identify plants for removal*
- + *plant and maintain new gardens*



## GARDEN FEATURES

### MAKING A GARDEN

A garden differs from an overgrown lot in that it is managed and cared for. There are many kinds of gardens: formal bosque grids, naturalized beauty strips, wild and wooly interplanted meadows, and beyond. This section explains how gardens can be created through two techniques, SUBTRACTION and ADDITION.

A GARDEN BY SUBTRACTION relies on the existing vegetation of the edge to create new gardens. Plants have a natural tendency to spontaneously grow and spread, which can be intentionally designed through subtraction and management.

A GARDEN BY ADDITION defines you lot edge through the addition of new planting and through regular maintenance. A greater level of maintenance is required, however this yields a greater amount of control over the appearance of the garden.

### GARDEN TYPES

**GRID** | Grid planting has clean lines and an obvious logic to their layout. Think a row of trees or a flower cutting garden. These gardens select a few plants and organize them carefully. They require more effort to maintain this order than a naturalized or interplanted garden.

**NATURALIZED** | Naturalized planting does not have hard lines or even edges. These gardens include meadows, for example, and tend to be less tightly controlled in their design.

**INTERPLANTED** | Interplanting can amplify landscapes by adding specific plants here-and-there. Once introduced, interplanted gardens can grow and change on their own and are mores spontaneous.

## CONSIDERATIONS

### RESOURCES

This chapter includes an extensive list of recommended plant species, including large trees, medium tree, shrubs, perennials and grasses. Use this list to help guide your plant choices as well as a list of resources provided on page 75 for local plant nurseries, online resources, and plant identifying phone apps!

### PLANNING

Be sure to refer to Chapter 2 pages 40-43 first to assess your lot. Do you have invasive species? Is there a big, beautiful tree you want to keep? Determining what you have will help dictate what garden you should create! Next, consider what tools and help you have. Can you clear shrubs and invasives alone or will you need help? How big is your lawn mower? You will begin by subtracting plants and then adding new ones to the site.

### IMPLEMENTATION / CONSTRUCTION

Follow the instructions on page 18 + 19 to layout your new plants. Installation can be a quick part of the process in transforming your site.

### MAINTENANCE

Maintenance is a key component of the garden, but it doesn't have to be difficult. Watering, weeding, pruning, and mowing are important to keeping a site looking cared for.

Trees will require upfront maintenance and regular watering, but will eventually be self-sufficient. Perennials will require more regular watering and maintenance as they grow and evolve.



# GARDEN BY SUBTRACTION

Overgrown lots have great potential to become spontaneous gardens through management and subtraction techniques. Gardens by Subtraction can be created on edges or the whole lot. Through subtraction you're a part of the process but the plants are running the show, you're guiding it!

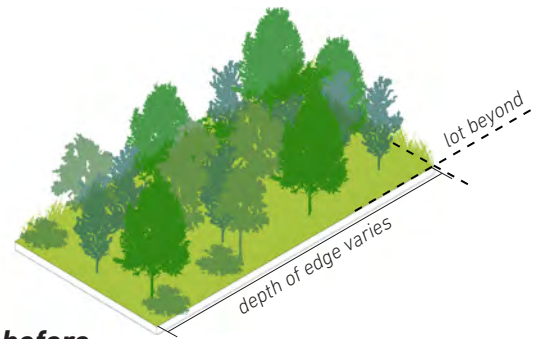
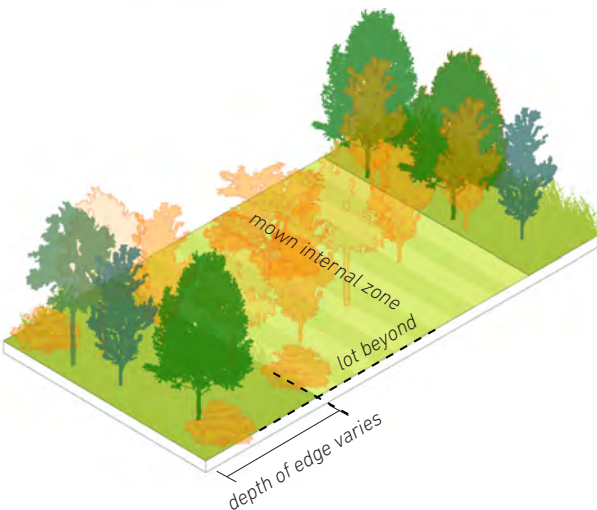
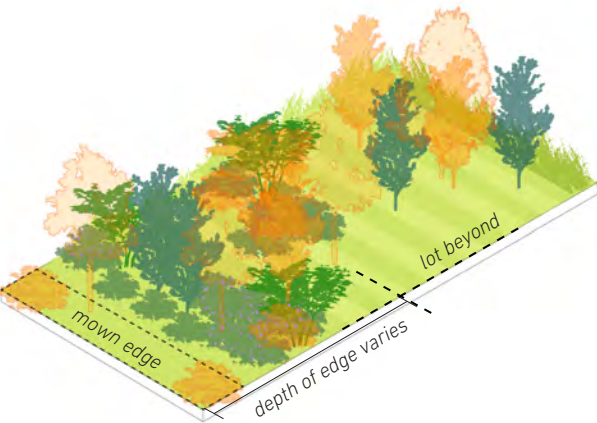
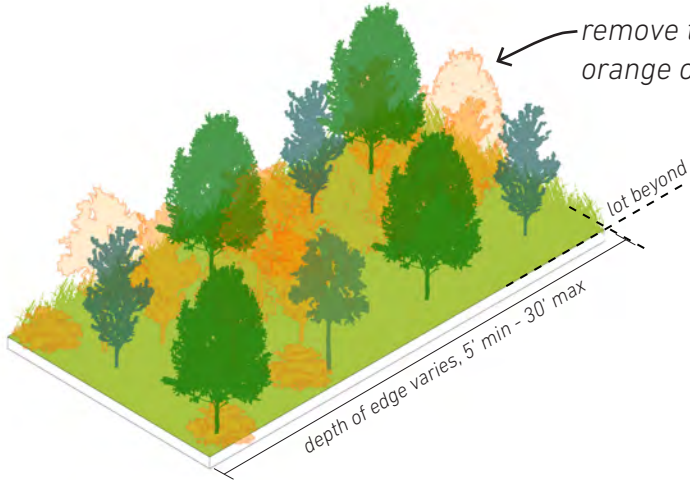

## GRID / BOSQUE

**Create Formal Order | Increase Visibility**

Forming a bosque on your lot involves thinning out existing vegetation to increase under-story visibility, create more organization of the trees, and offer the existing trees that are kept more space to thrive.

## INTER-PLANTING / GARDEN PATCHES

**Create Habitat | Add Color**

Clearing to create defined garden patches allow for moments of beautiful plantings to be grouped along an edge. They create a dynamic relationship between mown areas and taller grasses and flowers. These edges look more natural, but are still managed and maintained.

## NATURALIZED / BEAUTY STRIP

**Prevent Dumping | Add Formal Order**

Clearing vegetation to define a beauty strip. Beauty strips are lines of planting that form a border along the edge of a lot. Beauty strips add a aesthetic value to your lot while blocking access and preventing illegal dumping. This strip is created by LEAVING the vegetation by the street, removing internal trees and shrubs and mowing larger areas.



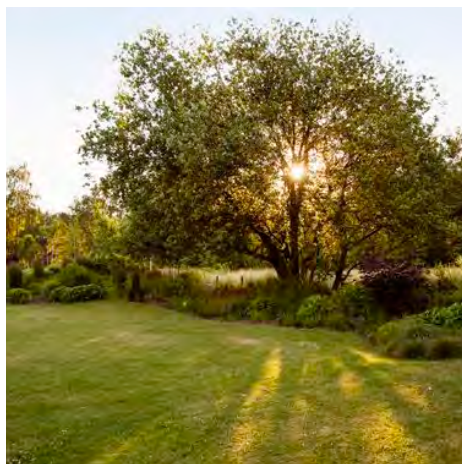

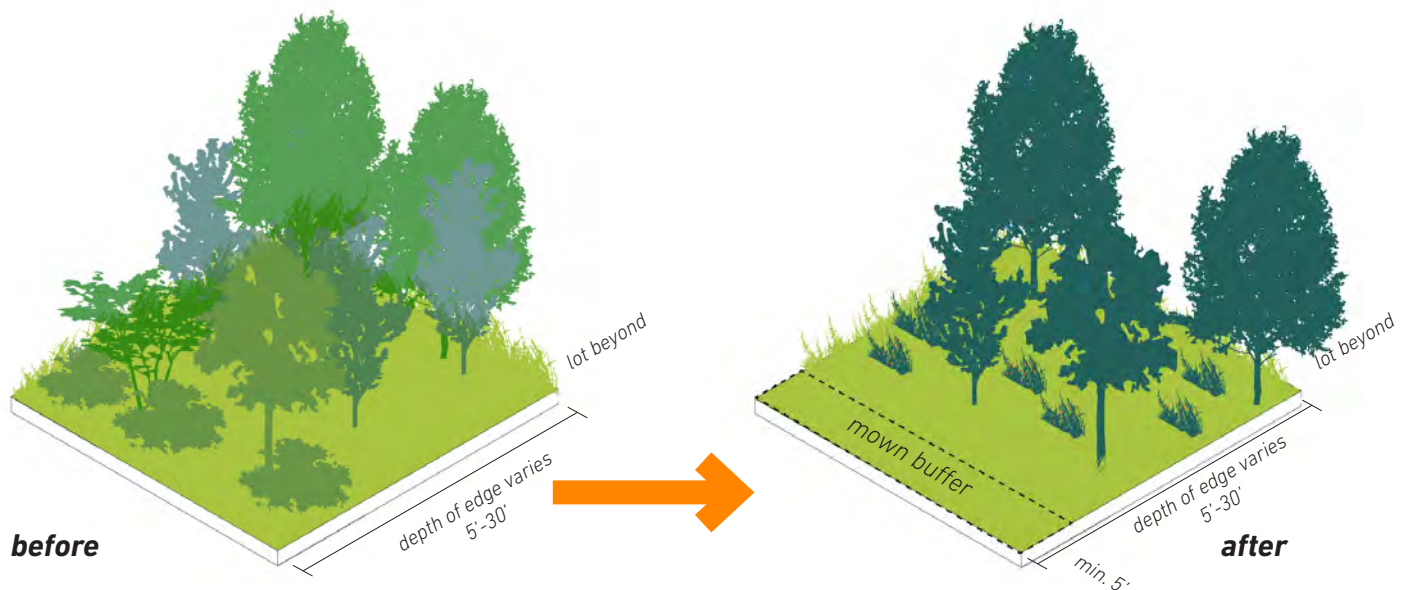

## MAKING A GARDEN BY SUBTRACTION

### REMOVE INVASIVES + DEAD TREES:

Identify invasive species, dead trees and shrubs for removal (see plant list on pg. 38). Be mindful of poison ivy and wear gloves to protect yourself while removing plants.

### PRUNE + TRIM OVERGROWN PLANTS:

1. Identify trees and shrubs you will keep on the lot. A healthy, established non-native tree can provide benefit through shade, habitat, and beauty. Look for single stem trees with a strong leader.
2. Use sharp pruning sheers for small removal or loppers for large removal to cut dead branches. Use loppers to limb up trees to create more visibility, being mindful not to remove the leader (see drawing below).
3. Cut back excessive growth using a weed whacker or lawn mower.
4. If you need to cut down larger trees, the use of chain saw may be necessary with extreme care for power lines.

**CREATIVE MOWING:** Once you have identified species to keep, you can mow around them to clean up the edges of the shrubs and open views. Creative mowing ideas include keeping some patches of grass tall, mowing every 5 feet, cutting winding paths through meadow, and beyond! Creative mowing can create visual intrigue with plants through minimal tools and effort.

**AMEND SOILS:** Existing soils on your lot may be depleted of nutrients and compacted. Amending soils adds air and important nutrients back into the soil so that new plants may grow more easily. To amend soils, add an organic soil amendment compost or peat moss and mix it into the soil where you intend to plant.





**REMOVE INVASIVES** | Invasive vines like these should be removed to protect the health of other trees



**REMOVE INVASIVES** | Ailanthus (Tree of Heaven) is an invasive rapid-spreading shrub or tree that should be removed to prevent continuous spreading



**DEAD TREES** | Cutting back overgrown lots and dead trees requires sharp saw, loppers, and pruning shears



**PRUNE** | Identify the leader on a tree or shrub and keep it intact, which removing competing branches



**CLEARING UNDERSTORY** | leaving some trees can create a playful path

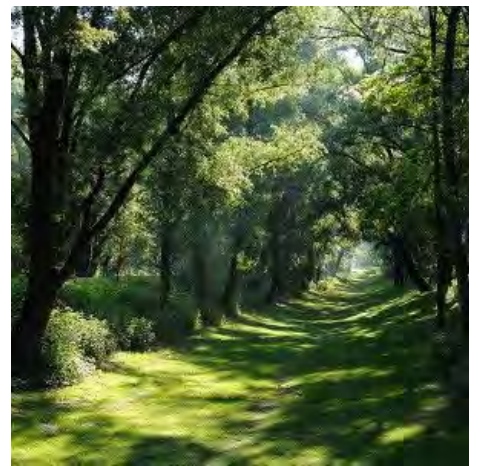

**CLEARING UNDERSTORY** | and trees through a lot while maintaining some trees can create a lush path



**CREATIVE MOWING** | Consider the size of your mower and how wide a path it will create. Leaving some grass unmown will create spaces on your lot



**CREATIVE MOWING** | Consider leaving flowering plants unmown. Mowing around these plants will add interest and beauty to your lot!



**AMEND SOILS** | You turn new amendment into the ground with your hands for small areas or with rented equipment for larger areas



# GARDEN BY ADDITION

Adding plants to a lot edge is intended to enhance usefulness, ecological function and aesthetic quality. Trees, shrubs, and flowers can be added to an edge to beautify it, protect it, or organize it. Using grids and clean lines to lay out your edges will keep it looking tidy and intentional!

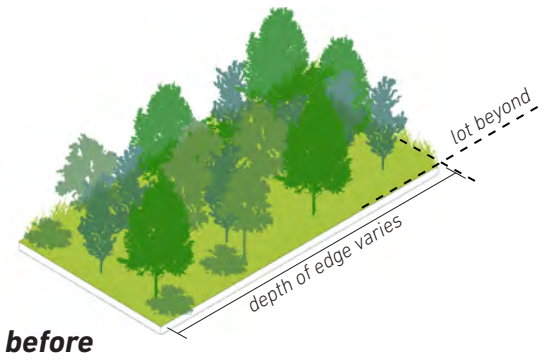

**before**

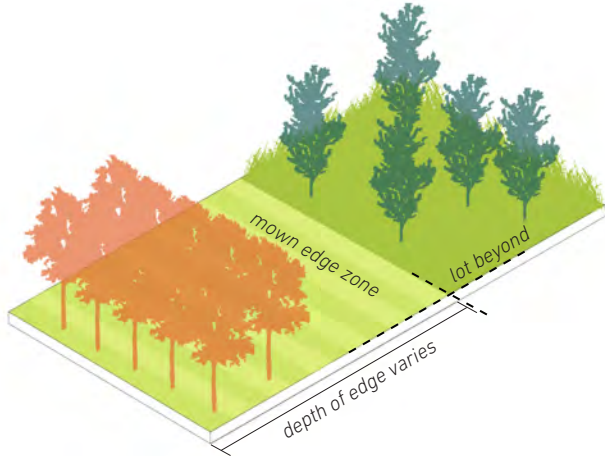

## GRID / ALLEE EDGE

**Prevent Dumping | Frame Your Lot**

These edge plantings are spaced equally in linear, carefully measured rows and serve as a continuous buffer of trees for shade and beauty. The allee works well for multi-lot projects where the rows can continue down a half or full block.

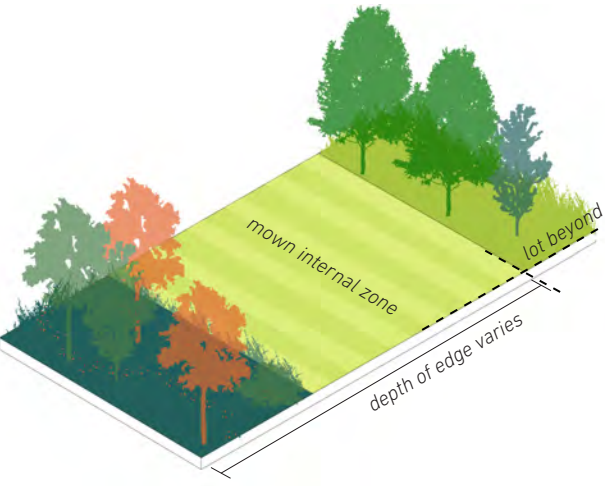

## NATURALIZED / GARDEN EDGE

**Prevent Dumping | Frame Your Lot**

Dumping prevention/beauty strips can also be created by ADDING plants to your lot edge. This would work best of fairly empty lots prone to dumping activity. Trees, shrubs, and tall grasses prevent access while providing beauty to the neighborhood.

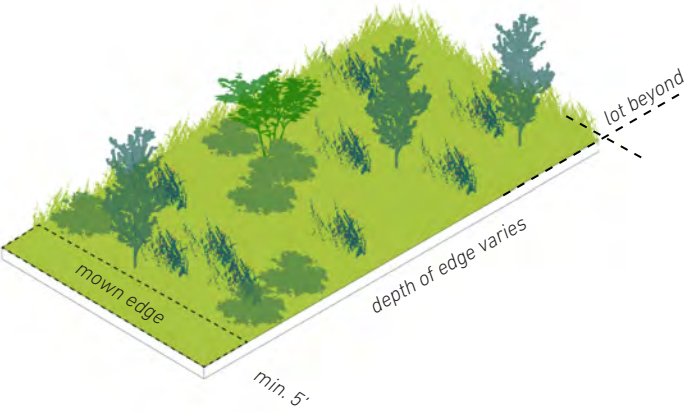

## INTER-PLANTED / MEADOW SAVANNA LOT

**Create Habitat | Add Seasonal Interest**

Creating a meadow means removing most of the tall vegetation from the edge of your lot. This will create clear lines of sight along the edge and into the lot as well as provide habitat for pollinators. This type of improvement will require removing existing vegetation as well as adding new pollinator-friendly flowers and grasses





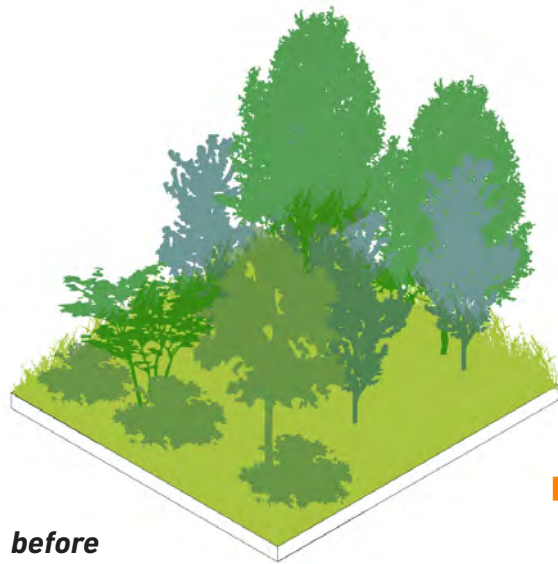

before

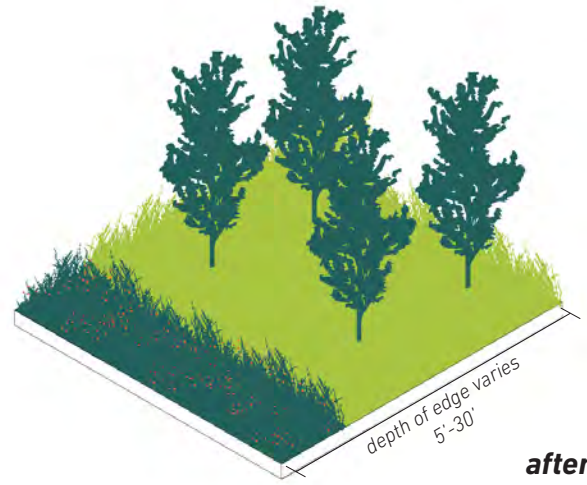

after

## MAKING A GARDEN BY ADDITION

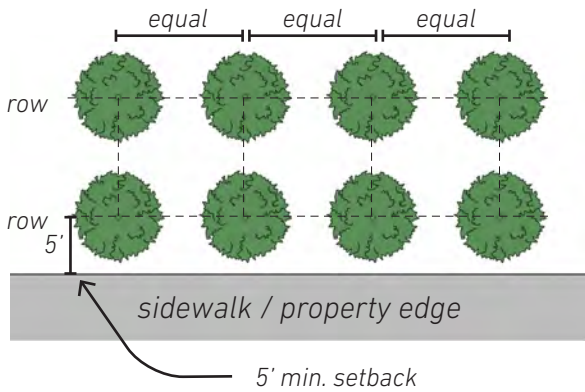

### TREE | GRID

**Step 01:** Using rope mark out your first grid row.

**Step 02:** Determine the tree spacing required for the tree species you would like to use and place stakes along the rope where you would like the trees to be installed. Generally, large trees will need 15'-20' and medium trees will need 10'-12'.

**Step 03:** Using the determined tree spacing as a minimum distance, mark out your next row. Two rows of trees will create an alley. Adding more rows will turn your tree planting into a bosque. To create an alley repeat step 2 and stake tree locations along the 2nd row. For bosque repeat steps 2 and 3 until desired size is achieved.

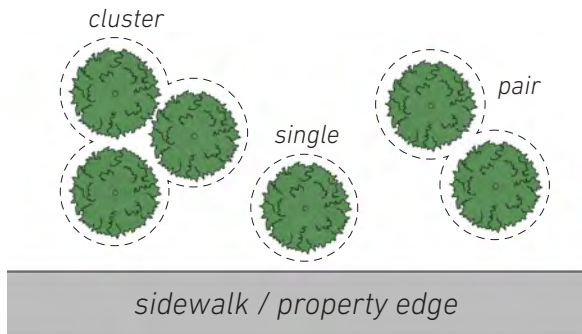

### TREE | NATURALIZED

**Step 01:** Determine the tree spacing required for the tree species you would like to use.

**Step 02:** Using those determined spacing requirements layout your trees in a series of Clusters, pairs and singles. Determine the tree spacing required for the tree species you selected. Generally, large trees will need 15'-20' and medium trees will need 10'-12'.

**Step 03:** Assess the layout and adjust accordingly to desired look.

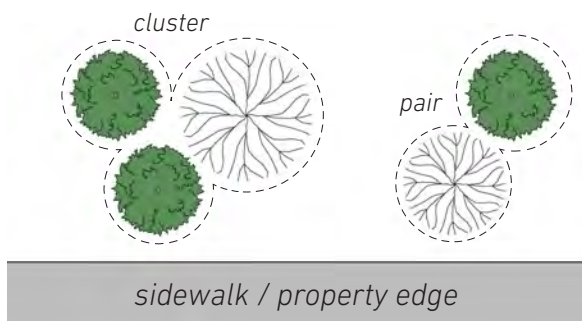

### TREE | INTERPLANTED

**Step 01:** Determine the existing trees you would like to layout new trees around. Remember these existing trees may be large and can cast a large shadow, preventing your new tree from getting sun.

**Step 02:** Using those determined spacing requirements for the new trees, layout your trees in a series of Clusters, pairs and singles.

**Step 03:** Assess the layout and adjust accordingly to desired look.





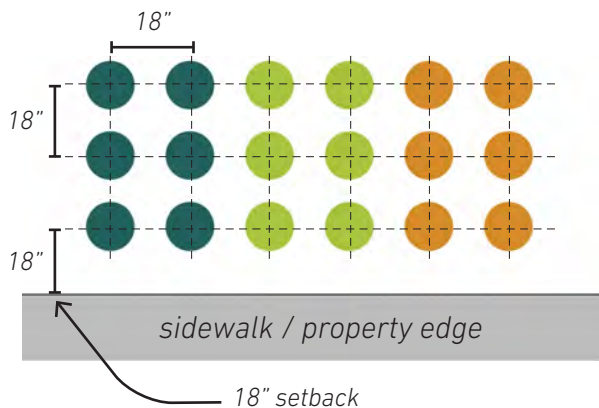

**PERENNIAL | GRID**

**Step 01:** Using an 18" space from center of plant stake out the space you would like to plant.

**Step 02:** Starting at one corner, start to place the same species of plants using 18" spaced rows. Planting the same species in large sections will give you bold colors and textures.

**Step 03:** Place all plants in their desired location before planting. Step back to look over the overall planting layout and adjust where needed.

**Step 04:** Keep plants in their locations desired location and start to plant each plant one by one.

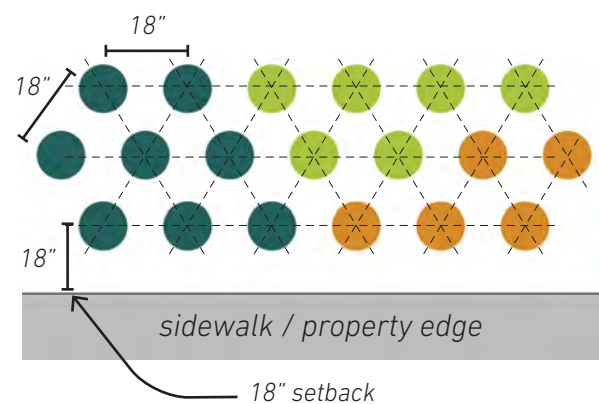

**PERENNIAL | NATURALIZED**

**Step 01:** Using an 18" space from center of plant stake out the space you would like to plant.

**Step 02:** Starting at one corner, start to place the same species of plants using 18" spaced rows. Planting the same species of plant in smaller clusters. Planting in smaller clusters will blend all the plants together and remove the bold definition of colors and textures. This planting layout creates a similar appearance to how you experience this plants in nature.

**Step 03:** Place all plants in their desired location before planting. Step back to look over the overall planting layout and adjust where needed.

**Step 04:** Keep plants in their locations desired location and start to plant each plant one by one.

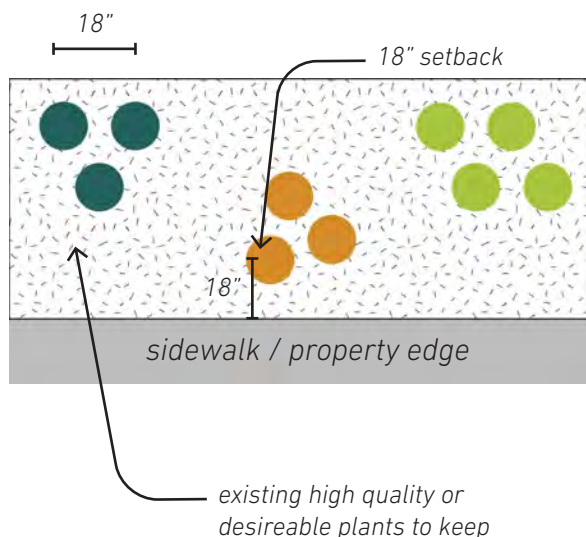

**PERENNIAL | INTERPLANTED**

**Step 01:** Using an 18" space from center of plant stake out the planting area around the existing plants.

**Step 02:** Starting at the existing plants, place plants you would like to complement first and move outward from there using 18" spaced rows. Planting the same species of plant in smaller clusters. Planting in smaller clusters will blend all the plants together and remove the bold definition of colors and textures. This planting layout creates a similar appearance to how you experience this plants in nature.

**Step 03:** Place all plants in their desired location before planting. Step back to look over the overall planting layout and adjust where needed.

**Step 04:** Keep plants in their locations desired location and start to plant each plant one by one.

**See the list of TREES, SHRUBS, and PERENNIALS starting on page 20 for suggested species to consider for your garden!**



# PLANT LISTS

## ADD - ADAPTABLE PLANTS TO BE ADDED TO THE SITE

Trees, shrubs, and perennials listed below are good choices for plants that could be ADDED to your lot. These plants add beauty, ecological diversity, and interest to your lot edges. Each species has different characteristics and behaviors that make it better suited to certain types of planting. Use the matrix on the right to determine which species to use depending on what type of garden edge you wish to create.

### LARGE TREES

		INTERPLANTING GRID	NATURALIZED	SCREENING
Acer x freemanii	Freeman Maple		x	x
Acer rubrum	Red Maple		x	x
Aesculus glabra	Ohio Buckeye		x	
Aesculus hippocastanum	Horse Chestnut		x	
Betula nigra	River Birch	x	x	x
Cladrastis kentukea	Yellow Wood	x	x	x
Ginkgo biloba	Ginkgo		x	
Gymnocladus dioicus	Kentucky Coffee Tree		x	
Liquidambar styraciflua	Sweet Gum	x	x	x
Liriodendron tulipifera	Tulip Tree	x	x	
Nyssa sylvatica	Tupelo	x	x	x
Picea pungens	Colorado Blue Spruce	x	x	x
Pinus strobus	White Pine	x		x
Platanus x acerifolia	London Plane Tree		x	x
Pseudotsuga menziesii	Douglas Fir	x	x	x
Quercus bicolor	Swamp White Oak		x	x
Quercus coccinea	Scarlet Oak		x	x
Quercus ellipsoidalis	Northern Pin Oak		x	x
Quercus macrocarpa	Burr Oak		x	x
Quercus palustris	Pin Oak		x	x
Quercus rubra	Red Oak		x	x
Taxodium distichum	Bald Cypress	x		x
Thuja plicata	Giant Arborvitae		x	
Tilia cordata	Little Leaf Linden	x	x	x
Tilia tomentosa	Silver Pendant Linden	x	x	



INTERPLANTING  
GRID  
NATURALIZED  
SCREENING

**MEDIUM TREES**

Amelanchier arborea	Shadblow	x	x	x	
Carpinus caroliniana	American Hornbeam	x	x		
Carpinus betulus	European Hornbeam	x	x		
Cercis canadensis	Eastern Redbud	x		x	
Cornus florida	Flowering Dogwood	x	x	x	
Cornus kousa	Kousa Dogwood	x	x	x	
Juniperus virginiana	Red Cedar	x	x	x	x
Magnolia x soulangeana	Saucer Magnolia	x		x	
Magnolia stellata	Star Magnolia	x		x	
Malus floribunda	Japanese Flowering Crabapple	x	x		
Malus spp. (disease resistant)	Flowering Crabapples	x	x	x	
Ostrya virginiana	Hop Hornbeam	x	x	x	
Prunus cerasifera	Purpleleaf Plums	x	x		
Prunus sargentii	Sargent Cherry	x	x		
Prunus serrulata 'Kwanzan'	Japanese Flowering Cherry	x	x		
Prunus x yedoensis	Yoshino Cherry	x	x		
Syringa reticulata	Japanese Tree Lilac	x	x		
Thuja occidentalis	Arborvitae	x	x		x

**EDGE SHRUBS**

Aesculus parviflora	Bottlebrush Buckeye	x	x	x
Aronia arbutifolia	Red Chokeberry	x		x
Cornus racemosa	Gray Dogwood	x		x
Cotinus coccigria 'Royal Purple'	Royal Purple Smoke Bush	x		x
Hamamelis x intermedia cultivars	Spring Blooming Witchhazels	x		x
Hibiscus syriacus 'Lil Kim'	Lil Kim Rose of Sharon		x	x
Hydrangea arborescens	Smooth Hydrangea		x	x
Hydrangea paniculata	Panicle Hydrangea			x
Hydrangea quercifolia	Oak-leaf Hydrangea			x
Ilex verticillata cultivars & hybrids	Winterberry holly	x	x	
Rhus aromatica 'Gro-Lo'	Fragrant Sumac	x		x
Rhus copallinum	Shining Sumac	x		x
Rhus typhina	Staghorn Sumac	x		x
Sorbaria sorbifolia	Ural False Spirea	x	x	x



**PERENNIALS**

INTERPLANTING  
GRID  
NATURALIZED

Asclepias tuberosa	Butterfly Weed	X		X
Aster laevis	Smooth Aster	X	X	X
Coreopsis verticillata 'Moonbeam'	Tickseed	X	X	X
Dryopteris erythrosora	Autumn Fern	X		X
Eupatorium maculatum	Joe Pye Weed	X	X	X
Echinacea purpurea	Purple Coneflower	X	X	
Helianthus maximilliana	Maximillian Sunflower		X	
Helleborus foetidus	Stinking Hellebore	X	X	X
Heuchera spp.	Coral Bells	X	X	X
Hibiscus spp.	Swamp Rose Mallow	X	X	X
Liatris spicata	Prairie Blazing Star	X		X
Lobelia cardinalis	Cardinal Flower		X	X
Monarda didyma	Bee Balm	X		X
Nepeta faassenii	Catmint	X		X
Perovskia atriplicifolia	Russian Sage	X	X	X
Rudbeckia fulgida 'Goldstrum'	Goldstrum Black Eyed Susan	X	X	
Rudbeckia subtomentosa	Black Eyed Susan	X	X	
Rudbeckia tiloba	Brown Eyed Susan	X	X	

**GRASSES**

Muhlenbergia capillaris	Pink Muhly Grass
Schizachyrium scoparium 'Standing Ovation'	Little Bluestem

**SUBTRACT - PROBLEMATIC TREES TO BE EVALUATED**

See Chapter 2 Lot Assessment for a list of trees that should be REMOVED to ensure your lot is healthy and diverse in its vegetation. This list includes species that are invasive, weak wooded, root suckering or otherwise problematic. Some species of trees are aggressive in their growing habits and make it hard for other plants to succeed. Others species to avoid include plants that are prone to insect or disease. The plants on this list in Chapter 2 are also species that should not be added to a lot.



## **ENHANCEMENTS - PROBLEMATIC TREES TO BE EVALUATED**

These are examples of trees that can be left to grow on a lot to ENHANCE the landscape if they are healthy and have good form. See Chapter 2 Lot Assessment to learn about the characteristics of health and good form. Species that do not meet these characteristics should be removed.

### **PROBLEMATIC TREES**

Acer plantanoides	Norway Maple
Alnus glutinosa	Black Alder
Betula pendula	European white birch
Carya cordiformis	Bitternut Hickory
Catalpa speciosa	Hardy Catalpa
Celtis occidentalis	Hackberry
Malus spp.	Flowering Crabapples
Morus alba	Common Mulberry
Morus rubra	Red Mulberry
Populus deltoides	Eastern Cottonwood
Tilia americana	American Linden
Ulmus pumila	Siberian elm

### **ADDITIONAL RESOURCES**

#### **PLANT NURSERIES**

English Gardens  
22650 Ford Rd, Dearborn Heights  
(313) 278-4433

22501 Kelly Rd, Eastpointe  
(586) 771-4200

4901 Coolidge Hwy, Royal Oak  
(248) 280-9500

#### **PLANT ID**

I-Naturalist App  
[www.inaturalist.org](http://www.inaturalist.org)

UM Herbarium  
[www.michiganflora.net](http://www.michiganflora.net)



# GARDEN POSSIBILITIES

## Edges can hold water

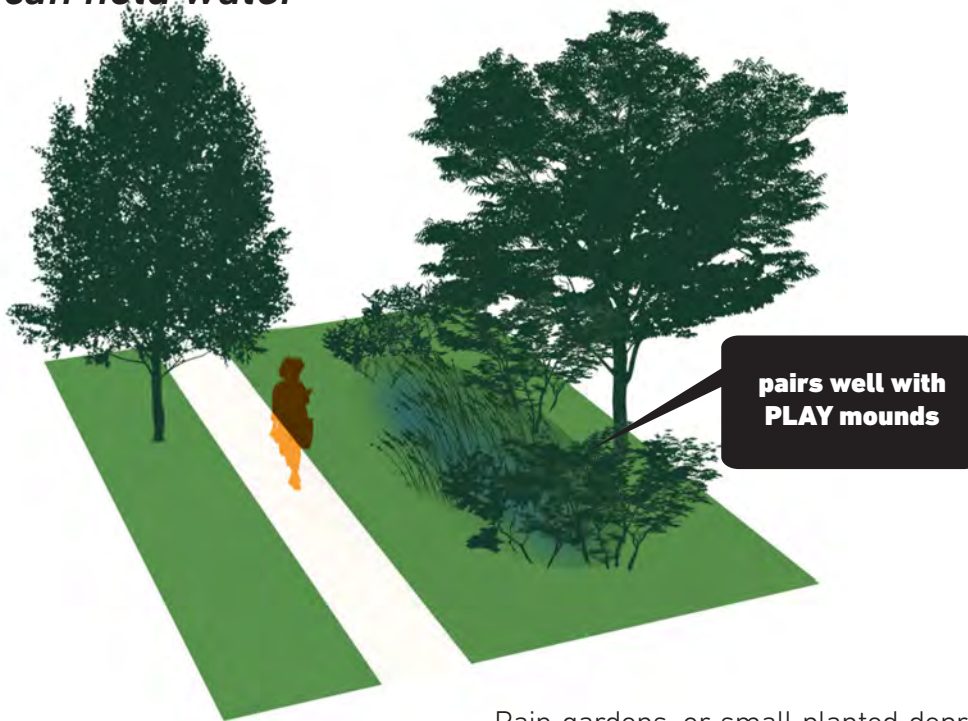

Rain gardens, or small planted depressions, can help alleviate minor areas where flooding and ponding persist. They can store and filter water after large rain events. Additional resources can be found here: <https://therouge.org/diy-rain-garden-guidance/>

## RAIN GARDENS

- + MINIMIZE PONDING AND FLOODING
- + PROVIDE ECOSYSTEM SERVICES
- + ADD BEAUTY
- + CREATE HABITAT



## LAYOUT INSTRUCTIONS

### Step 01 – Select Location and determine the size

A rain garden should be located downhill and at least 15' away from any structures to avoid water damage. It should be able to have access to down spouts from the roof or natural swales away from a driveway. The size of the rain garden will vary based on the size of the catchment area (roof and surrounding surfaces that all drain to the same area). You can use an online calculator to help you determine the size and to understand how well your soils will infiltrate the water. Expect to pay \$2/square foot if you do it all yourself.

### Step 02 – Prepare the site

Stake out the shape of the rain garden. Once the shape is set remove all ground cover and dig out hole deep enough to pool 3" of water. When digging out the hole, make sure the lowest spot is at the center. Direct downspouts to the rain garden.

### Step 03 – Plant selection

Choosing the right plants for the rain garden is crucial to make sure that the plants can tolerate periods of drought as well as being inundated in water. A Detroit-specific plant list and additional guidance can be found using the link above and following their step by step guide to Rain Gardens.

### Step 04 – Maintenance

Expect to water regularly for the first season to reduce mortality. After the first year, native plants need only be watered during very dry weather.



# GARDEN POSSIBILITIES

## Edges can support urban agriculture

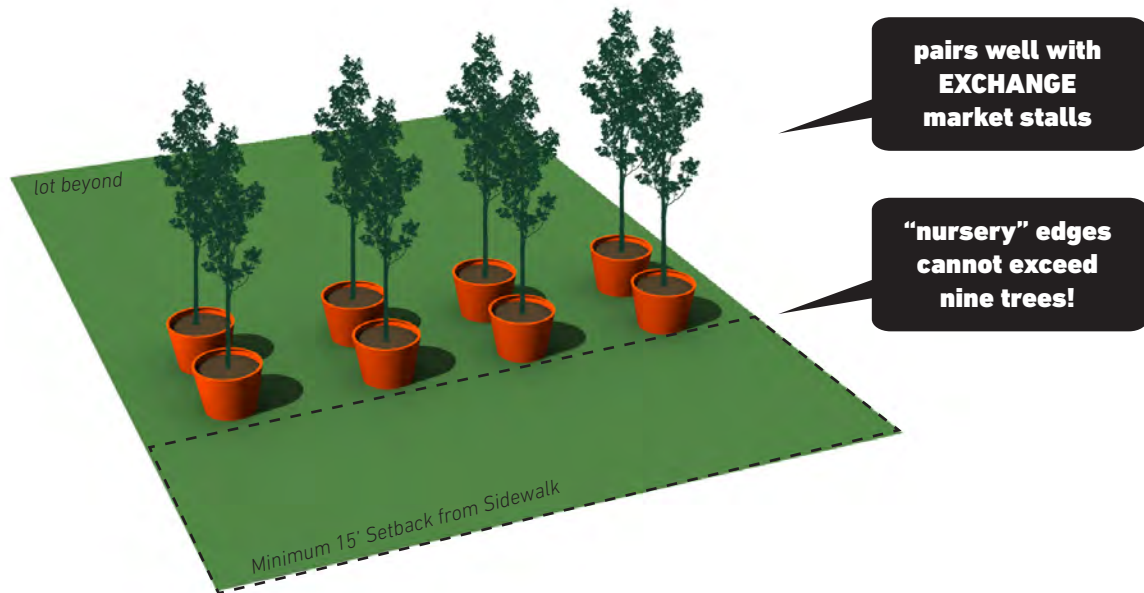

Creating an urban nursery will provide a resource to the neighborhood. Trees are kept in pots so they can easily be moved to their new lots. An urban nursery does require a high input of cost to establish and require regular care and attention.

## URBAN NURSERY

- + RESOURCE FOR THE COMMUNITY
- + MIGHT REQUIRE GRANT FUNDING

### LAYOUT INSTRUCTIONS

#### Step 01 – Why create a nursery?

A small community tree nursery can be helpful in growing trees for the neighborhood in a cost effective way. Buying/Growing trees from a young age allows you to pay for the cost of a sapling and use time as your investment instead of spending a lot of money for bigger trees at a nursery.

#### Step 02 – Select Location

Finding the right spot that provides sufficient space for trees to grow in place for year(s) in their containers is crucial. Having to relocate a bunch of trees will not be fun. A near by water source is essential to make for an easy watering and help trees thrive.

#### Step 03 – Monitor the trees

Trees growing in containers do not have the resources available that trees growing in the ground do. Watering regularly and making sure they never dry out is critical.

#### Step 04 – Let them grow

Apart for occasionally monitoring the trees, the only thing you need to do is let them grow. Each tree grows at it's own rate, so depending on the species being grown, the time investment will need to adjust to align with the growth rate of the species.





# GROUND

**GROUND** encompasses the surface materials beneath your feet. Ground can connect sidewalks to one another, it can define spaces to gather, it can be a thick path, a straight path, a winding or twisting path. Ground can be made of recycled and new materials, or can be created by mowing through taller plants. This section will tell you how to:

- + *choose the appropriate ground material*
- + *choose the appropriate form*
- + *construct and maintain a ground surface*



## GROUND FEATURES

### CREATING SPACES

Ground has the potential to do many things. Ground surfaces can help to connect one lot to another through a straight path. Ground surfaces can expand and contract to create a formal plaza. Ground surfaces can also define a space and tell users where to walk. Ground helps to create spaces and works with other edge typologies to bring an edge to life.

### GROUND MATERIALS

Ground materials are important to consider based on your intended use and the resources you have. Ground can be made of recycled and new materials, or it can be created by mowing through taller plants.

### GROUND FORMS

Your lot's location and your intended use for the edge will help determine what happens there. Is it a surface for walking from one place to another? Is it a space to put a bench and take a rest? Asking "what will happen here?" will help determine what the ground will look like.

## CONSIDERATIONS

### RESOURCES

Use pages 30-31 for instruction on how to create various types of Ground. Use pages 32-33 for inspiration on possible materials to use and spaces you can create very simply by designing the Ground!

### IMPLEMENTATION / CONSTRUCTION

Depending on the ground you wish to make, it take more or less time. All of the Ground options can be implemented in a day or less. Mown paths are the fastest way to create ground! Aggregate paths and steppers will take longer to construct, but will create a more permanent and formal surface.

### PLANNING

Before you choose the material for the Ground, consider what you want to happen on your lot. Do you want to create a simple path? A place for kids to play? A larger space for people to gather? See page 80-81 to help in the planning process.

It is also important to understand what types of soils you have on your property and any potential contaminants before you go digging. Online resources to help you assess and test your soil can be found here: [https://www.michigan.gov/documents/mdard/Working\\_With\\_Soil\\_in\\_Urban\\_Areas\\_452152\\_7.pdf](https://www.michigan.gov/documents/mdard/Working_With_Soil_in_Urban_Areas_452152_7.pdf)

You should also consider what resources you have available to you, which will dictate what you can accomplish. Do you have a mower or can you borrow one from your neighbor? Do you have a excess brick or concrete from an old building ready to be used? Knowing this before you start will help in implementation.

### MAINTENANCE

Ground is really easy to maintain! Lawn obviously requires some regular mowing to keep the lot occupied. Aggregate may need to be replenish if rain washes some of it away over time. Steppers may need to be replaced at times if they lift or sink.



# GROUND TYPES

Ground can be constructed through three simple material and maintenance strategies to create intentional surfaces on your lot: a crushed stone or gravel surface, turf or mown surface, and stone or concrete stepper surface.

## AGGREGATE

Crushed stone ground can transform a lot edge into a beautiful space or path. It is a relatively simple way to define the edges of a ground surface and create a stable surface to stand on.

**WHEN TO USE:** Best for uneven surfaces where crushed stone can fill in divets and conform to the existing topography of the lot. Crushed stone can be a simple way to formalize a path or gathering space.

**CONSIDERATIONS:** Crushed stone must be sourced and transported from a landscape supplier or hardware store which will add cost and time. Be sure to have a shovel, wheelbarrow, and a friend or two to help with the installation!



## MOWN PATH

Mown paths are a very simple way to create ground. Cutting a path through an overgrown lot can transform a lot that looks uncared for into an intentional and accessible space. Leaving some grass tall is what helps to define the ground. Mown paths can be placed for walking or as a buffer next to a sidewalk. The easiest path to create is that is the width of your mower.

**WHEN TO USE:** Best used as a temporary path or plaza. The beautiful thing about a mown path is that it will grow back, so experiment and have fun!

**CONSIDERATIONS:** A mown path or plaza will of course require a lawn mower, so consider this option only if you have a mower or can borrow one from a neighbor. Plan to re-cut the ground every month in the summer.



## STEPPERS

Steppers can be a formal or informal ground depending on how they are used. Square cut stone steppers are beautiful—though expensive—way to create a formal ground. Recycled concrete, brick, or natural stones can be a cheaper and less formal option to create ground surfaces.

**WHEN TO USE:** Best for smaller applications or when you have several hands to help. Stone steppers make a beautiful small plaza or path.

**CONSIDERATIONS:** Laying stone can be time consuming and expensive. Consider using recycled materials to save on cost and be aware of the size of the ground you want to create.



# GROUND TYPES



# GROUND CONSTRUCTION

## WHAT YOU NEED TO KNOW:

**TIME:** varies on size of paving zone  
**LEVEL OF EFFORT:** medium effort  
**NUMBER OF PEOPLE:** 2-3 people  
**COST:** \$\$  
**EXPERIENCE NEEDED:** basic measuring skills

## MATERIALS NEEDED:

PAVERS  
2" MINUS AGGREGATE  
SAND

## TOOLS NEEDED:

- TAPE MEASURE
- SHOVEL
- RUBBER MALLET
- LEVEL
- TAMPER
- BROOM

## AGGREGATE SURFACE

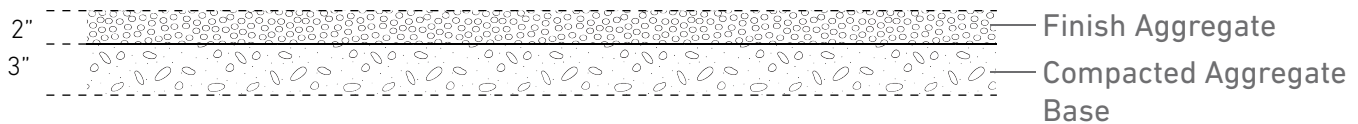

### STEP 01

The aggregate surface requires 3" of compacted base and 2" of a finish aggregate. This will give you a 5" thick surface depth. Remove 5" of soil where you would like to install and aggregate surface.

### STEP 03

Lay first 1" of finish aggregate over the entire paving area and compact the surface. Leveling and compacting the surface will start to lock the finish aggregate together to create a firm surface that doesn't move around. Repeat this process for the last 1" of finish aggregate to give you a solid usable surface.

### STEP 02

Once all of the soil has been removed to the depth required for the installation, you can start to lay 3" of compacted aggregate. When laying the aggregate it is important to be compacting as you build up the 3" depth. Once the 3" depth has been filled through out the entire paving area, go over the entire area one more time make sure everything is firmly compacted. Compacting can be done with a tamper, which can often be rented from local hardware stores.



## PAVED SURFACE

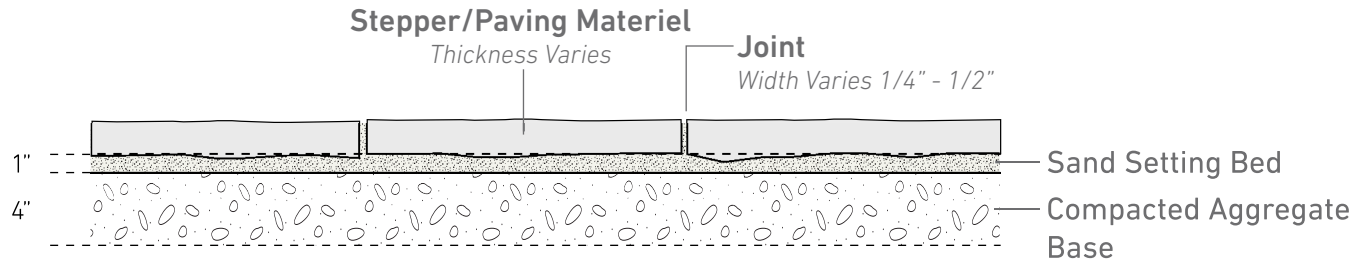

### STEP 01

Measure the thickness of the paving material to determine the depth you will need to dig for the paving installation. The paving material thickness may vary so try to find a thickness that best represents the average of each stepper. Averaging is not necessary with uniform paving materials. Take that measurement and add an additional 5" to have a depth that accounts for the sand setting bed and compacted aggregate.

### STEP 03

Lay 1" of sand over the entire paving area and start to set the paver materials in place. Leave a rough 1/4" spacing between all pieces as you place them. Level all paver pieces as you place them using a rubber mallet. Leveling the pieces will start to push the sand setting bed around which means the sand is properly filling the uneven voids of the pavers.

### STEP 02

Stake out the location of your path or surface using string and stakes. Use this as a guide as you remove soil. Remove existing soil to the depth of your paver width plus 5". This can be done with a shovel or backhoe. Once all of the soil has been removed to the depth required for the paver installation, you can start to lay 4" of compacted aggregate. When laying the aggregate it is important to be compacting as you build up the 4" depth. Once the 4" depth has been filled through out the entire paving area, go over the entire area one more time make sure everything is firmly compacted.

### STEP 04

Apply a thick layer of sand over the entire paving surface after all of the pavers have been set in place and leveled. Using a broom start to push the sand around the top of the paving surface. The sand will start to fill the spacing you left between the pieces and lock them in place. Repeat this process until all of the gaps between the pavers have been filled.

# GROUND POSSIBILITIES

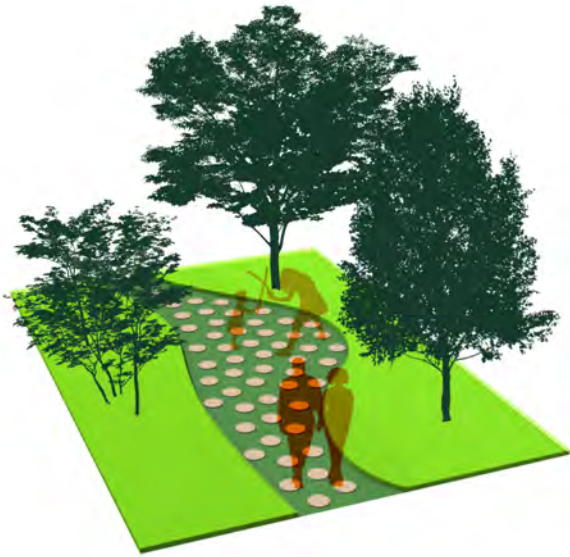

## **PLAYFUL PATH**

- + RECYCLED LOG SLICES
- + PLAYFUL, EASY-TO-INSTALL

Getting creative with the shape of your path will create interesting spaces. Existing trees can inform where you mow and what the path becomes. Log slices become 'steppers' to create visual interest. See the STEPPER instructions for more detail on how to create this path.

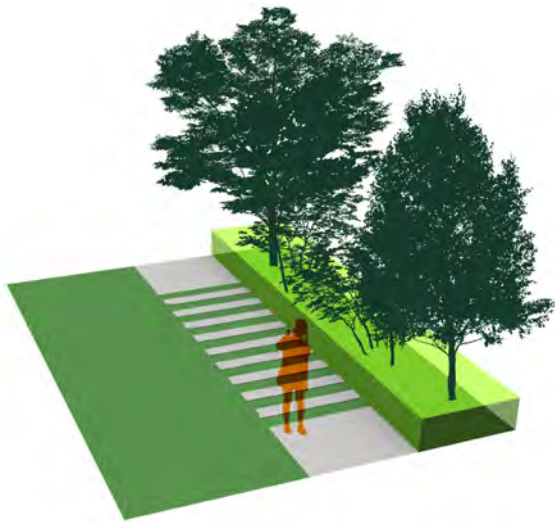

## **HOPSCOTCH LINK**

- + STRIPES OR SQUARES OF PAVERS AND AGGREGATE
- + CREATE CONNECTIONS

This pathway type can connect two sidewalks using recycled or new concrete slabs or bands of brick, depending on what might be available. These pathways take a fair bit of effort to install but have a unique character and are playful for children.



# GROUND POSSIBILITIES

## **PUZZLE PATH**

- + RECYCLED STONE OR CONCRETE
- + GARDEN OR SECONDARY PATH

The puzzle path can be created using a variety of recycled materials (concrete slabs, cobbles, stone or concrete pavers, bricks, log slices, etc). Putting it together is much like a puzzle; creators of this surface type will need to fit different sized stones together to create a larger surface.



## **PLACES TO PAUSE**

- + ZONES OF PAVING NESTED IN PATHWAYS
- + SMALL, INTIMATE PLACES TO SIT OR GATHER

When ground surfaces and paths get wider, they become spaces to put a bench or gather, like a plaza. The size of a place to pause can vary and can be constructed with any of the proposed materials here.

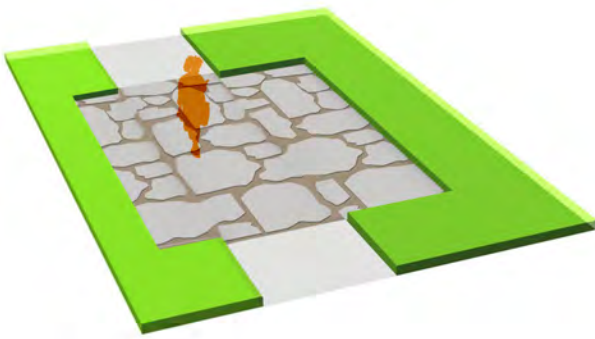

# IDENTITY

**IDENTITY** encompasses the features and colors that brand the neighborhood. Consistency in color, logo, and physical elements help to signify that you are in East Davison village. Consistent Identity also gives people the sense that this place is being cared for with intention.

**This section will tell you how to:**

- + *create a logo stencil and match color palette*
- + *construct the primary identity features*
- + *incorporate IDENTITY with other edge typologies*



## IDENTITY FEATURES

### CELEBRATING THE IDENTITY OF EAST DAVISON

The identity of East Davison Village can be emphasized and celebrated throughout the neighborhood through the use of color and materials. The following strategies can be employed on their own or together on lots and edges.

### VISUAL IDENTITY

**COLOR** | Using a consistent color palette makes the community feel cohesive! See page 125 for a full color palette for painting and stenciling lot elements.

**CONSISTENCY** | Like using consistent colors, using the same materials for identity, gather, and exchange elements will create a strong sense of place in East Davison Village.

**WELCOMING** | Identity posts can help welcome visitors and community members to the neighborhood. Identity posts can also serve as a place to post fliers and information about the community.

## CONSIDERATIONS

### RESOURCES

See the Glossary for templates for identity stencils. It is important to determine which type of paint is best suited to the surface you want to stencil. Ask at your local paint shop for suggestions.

Don't forget to refer to the color palette on page 125 of the Glossary to pick colors that will match other edge elements.

### PLANNING

When deciding where to add an Identity element it is important to consider the location of the element (will people be able to see it?) as well as what you are branding if using the Stencil.

If you are building a Beacon, call MISS DIG (800) 482-7171 or 811) to ensure there are no utilities where you want to place the post. If you are adding a stencil to something, measure the surface you want to stencil to ensure you create the right size template.

### IMPLEMENTATION / CONSTRUCTION

Identity stencils are easy to make! All you need is a printer, a utility blade, paint, tape. Beacons will create a day to build. You will need help lifting materials, cutting, and installing.

### MAINTENANCE

Identity elements are easy to maintain. Stencils can be touched up using small brushes if they start to fade, beacons may need to be touched up if painted.



# IDENTITY TYPES

The three typologies for Identity include a Welcome Beacon, Logo Stencil and Color Block Planting. These three elements can be used with any of the five other typologies as very simple way to add color and neighborhood branding to a lot.

## WELCOME BEACON

The beacon can be located alone or with others at the edge of any lot as both an identifying marker and as a place for community members to post fliers for events and organizations. The marker is a colorful and simple way to signify that you are in East Davison Village. It incorporates the Logo Stencil as a part of the design.

**WHEN TO USE:** Best along the edge of a lot and at intersections so that people can see it! Anchor locations (significant and visible lots at the corners of the neighborhood) are ideal locations for a Welcome Beacon. See the Neighborhood Quilt Plan in the Introduction for these locations.

**CONSIDERATIONS:** The Beacon is a simple construction, but be aware of possible gas lines before you dig.



## LOGO STENCIL BRANDING

This Logo Stencil is the simplest way to reinforce Identity in the community. The logo can be used on all of the constructed features within the six typologies, on benches, a stage, the welcome beacon and beyond!

**WHEN TO USE:** Use the stencil on any typology you construct to create a consistent brand for the neighborhood

**CONSIDERATIONS:** Look at the EDV color palette and consider the colors of the element that you are adding a logo to. Is it raw wood or painted? Will this color stand out on the element? These are important things to consider when painting the stencil. Be sure that you are using the stencil included in the appendix to create a consistent logo.



## COLOR BLOCK PLANTING

Color block planting creates a beautiful, bold and legible strip of color that can help create a unique East Davison Village identity. Picking a single species of perennial will create a cohesive experience on your lot edge.

**WHEN TO USE:** Create a color block planting strip when you want to prevent dumping and add a pop of color to your lot!

**CONSIDERATIONS:** Planting will require maintenance. Trees should be spaced close enough to restrict access to the lot while still leaving enough space for the trees to grow and thrive.



# IDENTITY



# IDENTITY

## WELCOME BEACON

### WHAT YOU NEED TO KNOW:

**HOURS:** 4-5 hours

**LEVEL OF EFFORT:** Medium effort

**NUMBER OF PEOPLE:** May need help cutting, lifting and installing

**COST:** \$\$

**EXPERIENCE NEEDED:** Experience with a saw, stenciling, and painting.

**MAINTENANCE:** Identity posts require little maintenance. They may need to be repainted once a year after the winter has passed.

### MATERIALS NEEDED:

- O (2) 2X6 - 8' DOUGLAS FIR BOARDS
- I (2) 2'X2' 3/4" PRESSURE TREATED PLYWOOD
- K (1) 6X6 - 14' DOUGLAS FIR POST
- F (35) #12 EXTERIOR SCREW (3"-4" L)
- +PAINT

### TOOLS NEEDED:

- TAPE MEASURE
- PENCIL
- POWER DRILL
- DRILL AND FASTENING BITS
- CIRCULAR SAW
- PAINT BRUSH

### STEP 01 parts - K(1)

Mark and dig a hole for the beacon using a post hole digger. The post (K) should be buried at least 4' in the ground to prevent any movement during the winter freeze/thaw cycle. Once post is placed in hole, start filling the hole back with the soil removed. Make sure to that the post is level and the soil is firmly compacted.

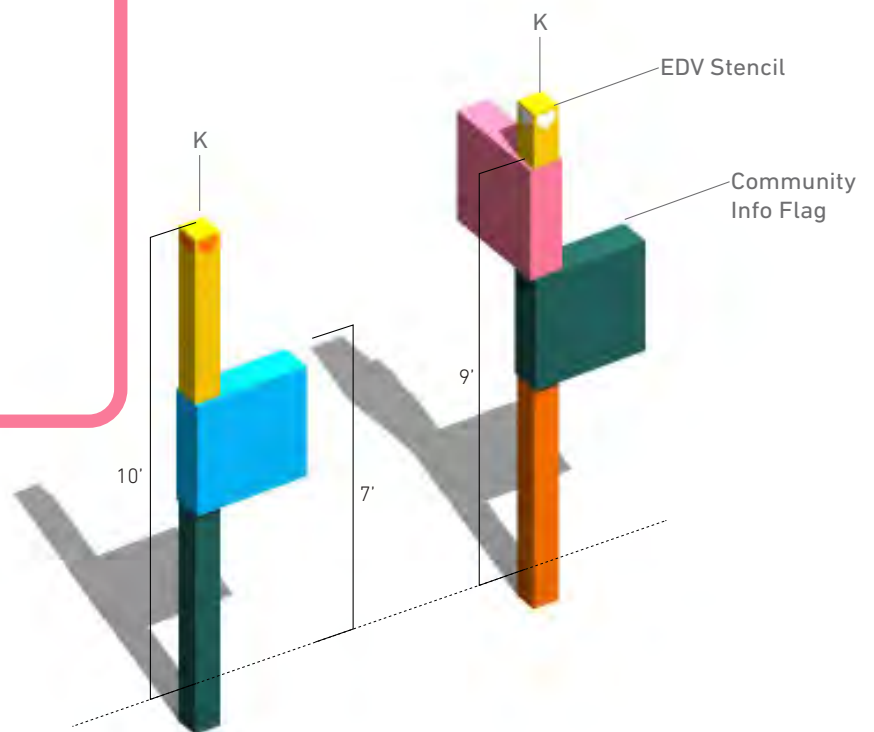

# IDENTITY WELCOME BEACON

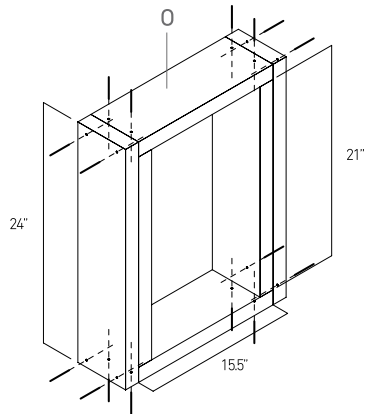

## STEP 02 parts - O(2-24", 2-21", 2-15.5")

Start by cutting the 2x6's into the 6 pieces required to build the flag frame. To assemble the flag frame fasten O pieces together using part F screws with a cordless drill. This step creates one flag frame; multiple this step by the number of flags needed.

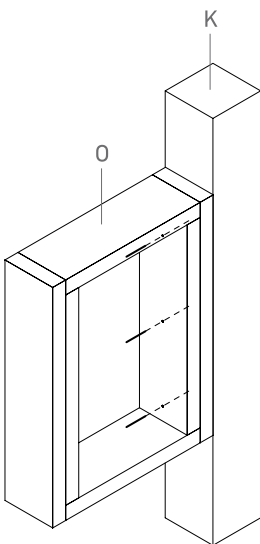

## STEP 03 parts - Flag Frame

Fasten flag frame to post(K) using part F screws. When attaching make sure frame is aligned evenly with post and top of flag is marked on post. Top of flag attachment locations are 1' and 3' from top of post.

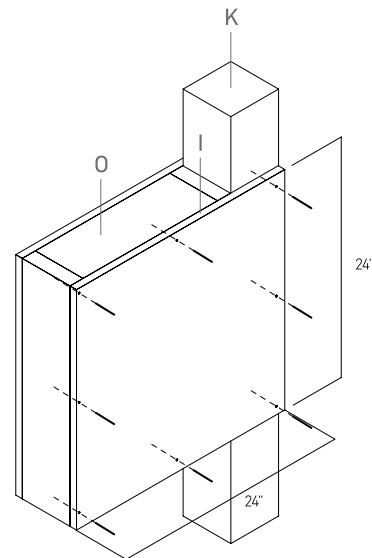

## STEP 04 parts - I (2)

Once flag frame has been secured to post, attach plywood piece(I) to both faces of the frame. The plywood will be secured to the post on one edge and the frame on the other edges. Piece(I) does not need to be cut to size.



# IDENTITY

## COLOR BLOCK PLANTING

### WHAT YOU NEED TO KNOW:

**HOURS:** This could take a weekend

**LEVEL OF EFFORT:** Medium effort

**NUMBER OF PEOPLE:** You may need help turning soil or lifting trees into place

**COST:** \$\$-\$\$\$\$

**EXPERIENCE NEEDED:** None! Experience amending soil and planting could help.

**MAINTENANCE:** Identity color blocking gardens will need to be watered fairly often and occasionally pruned and weeded.

### MATERIALS NEEDED:

1-GALLON POTTED PLANTS; QUANTITY DEPENDS ON THE LENGTH OF YOUR EDGE  
PLANTING SOIL; 1 40LB BAG PER 9 PLANTS

### TOOLS NEEDED:

GLOVES  
SHOVEL  
SOMETHING TO WATER PLANTS WITH

**Color Block Planting can help prevent dumping and has a high visual impact!**



*Signs of healthy plants at nurseries include intact leaves and stems, free of spots or bumps of any kind, and have signs of new growth*



*This is a 1-gallon pot! Look for this at the store.*

### STEP 01 plan your edge

Draw out your plan for the edge. Determine how many potted plants you will need and if you are adding trees, determine how many trees you will need. Picking a single, colorful plant will make a visual statement when planted in mass!

Plot out where you want to add planting and determine what tools you will use to turn and/or amend the soils. Soil turning can be done with a rake and shovel or with a rototiller. If adding planting soil, mix it in with the existing soil.



# IDENTITY

## COLOR BLOCK PLANTING

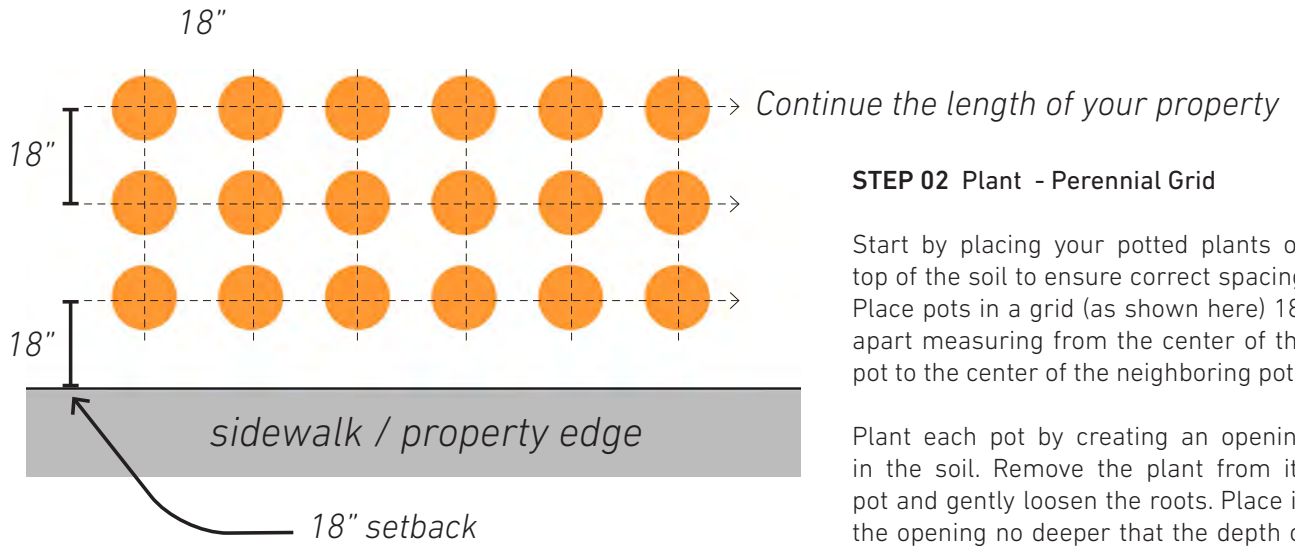

### STEP 02 Plant - Perennial Grid

Start by placing your potted plants on top of the soil to ensure correct spacing. Place pots in a grid (as shown here) 18" apart measuring from the center of the pot to the center of the neighboring pot.

Plant each pot by creating an opening in the soil. Remove the plant from its pot and gently loosen the roots. Place in the opening no deeper than the depth of the roots. Gently cover with soil and pat down firmly.

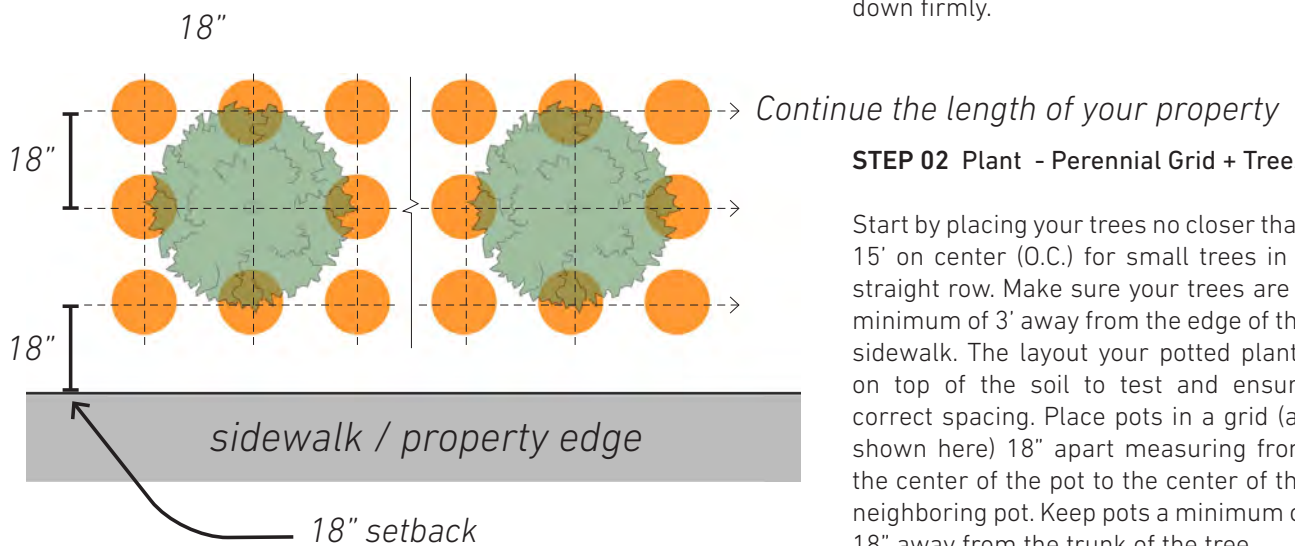

### STEP 02 Plant - Perennial Grid + Trees

Start by placing your trees no closer than 15' on center (O.C.) for small trees in a straight row. Make sure your trees are a minimum of 3' away from the edge of the sidewalk. The layout your potted plants on top of the soil to test and ensure correct spacing. Place pots in a grid (as shown here) 18" apart measuring from the center of the pot to the center of the neighboring pot. Keep pots a minimum of 18" away from the trunk of the tree.

Plant each pot by creating an opening in the soil. Remove the plant from its pot and gently loosen the roots. Place in the opening no deeper than the depth of the roots. Gently cover with soil and pat.

### STEP 03 Water

Water your new garden! New plants should be watered weekly depending on the weather. Continue to monitor your new garden for proper drainage (soil should not be soaked all the time). Local garden centers and nurseries are great for asking questions about any concerns that might arise.

see **page 66 + 67** for information about preparing soil to be planted!



# IDENTITY

## LOGO STENCIL BRANDING

### **WHAT YOU NEED TO KNOW:**

**HOURS:** This will take an hour or two

**LEVEL OF EFFORT:** Low effort

**NUMBER OF PEOPLE:** You can do this one on your own

**COST:** \$

**EXPERIENCE NEEDED:** None



### **MAKING A STENCIL**

Stencils are an easy way to celebrate the identity of East Davison Village. Single-use stencils can be made using average printer paper. Re-usable stencils can be made using the same process and a water-resistant paper, mylar, or other more durable materials. Making stencil requires a printer, paper or other material to cut the stencil out of, an x-acto knife, tape, a brush and paint or spray paint. **Layering stencils** is another way to add character. Creating a branded heart stencil requires layering two stencils together. First, the heart needs to be painted on, left to dry, and then the 'EDV' letters can be stenciled over it.

### **WHICH TYPE OF PAINT TO USE**

Different types of paint are suited to different situations. Spray paint is durable, easy to apply in light layers, and inexpensive. Stencils can also be used with outdoor, all season paint and a brush. If painting on the ground, only spray paint should be used as regular paint will wear off quickly.

### **CUSTOMIZING STENCILS**

East Davison Community Stencils can be customized to add other community organization names. See the glossary for a template for a customized stencil template.

### **PROFESSIONAL PRINT SERVICES**

Stencil templates can also be printed professionally. The benefit of professional printing is a higher selection of paper types.

### **DIY STENCIL TIPS**

- If you want to re-use the stencil, place the stencil template print-out under a sheet of MYLAR (available at craft stores) and then follow the same steps! Mylar is more durable than paper and can be washed and re-used.
- Always cut out your stencil on top of a spare piece of cardboard to avoid damaging tables. Using a utility blade to cut will be easier and more accurate than using scissors.
- Less is more! Build color in thin layers to avoid it bleeding under the stencil edges.
- Stencil templates can be resized by adjusting the 'zoom' function in print settings.
- See the Glossary for text and heart stencil templates!





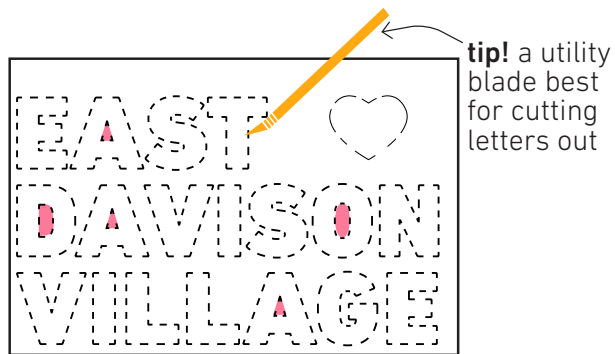

**STEP 1: SIZE TO DESIRED SCALE + PRINT STENCIL TEMPLATE**

Scale the template to your desired size and print out the stencil template. Prints can be scaled in the **print settings** screen.

**STEP 2: CUT OUT LETTERS SAVING THE PINK LETTER INTERIORS**

Using a utility blade or x-acto knife, cut out the letters and heart. Save the areas highlighted in pink!

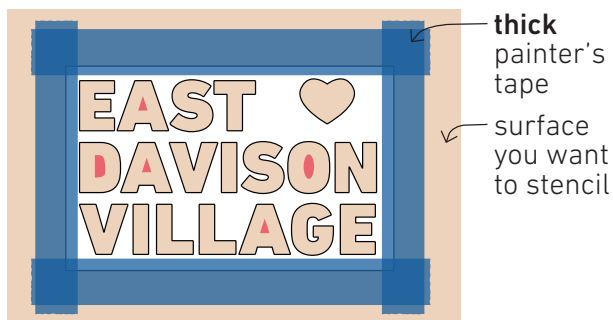

**STEP 3: ATTACH STENCIL + PINK AREAS TO SURFACE**

Tape the stencil to the surface you want to paint. Be sure to attach the pink areas you saved using small pieces of tape, too!

**STEP 4: PICK COLORS + PAINT!**

Paint over the stencil using small dabbing motions or a can of spray paint.



**STEP 4: REMOVE STENCIL + LET DRY!**

Remove the stencil and pink areas and let the area dry for at least 30 minutes.

**NOTE: LAYERING STENCILS**

Stencils can also be layered! Let base stencils dry completely before adding the next layer.





# PLAY

**PLAY** includes the designed features intended for play for all ages. Play opportunities can be created through existing materials, such as play mounds and mown paths, or through new constructed elements, such as balance beams and log hop. This section will tell you how to:

- + *select the right play features for your site*
- + *construct the primary play features*
- + *incorporate PLAY with other edge typologies*

## PLAY FEATURES

### A PLACE TO RUN, JUMP, BALANCE

Play edges are places for kids to gather in. They are active and energized spaces that come alive in the summer months and after school. Play edges have elements such as balance beams and log hops and are recommended for lots with good visibility and in close proximity to other edges.

### CREATING A PLAY EDGE

Play edges are easy to install. They are primarily made up of mowed areas, simple balance beams, and stumps to hop across. Because visibility is important, it is possible that future Play lots need to be heavily cleared prior to creating the edge.

## CONSIDERATIONS

### RESOURCES

There are a number of construction how-to resources online that can serve as a guide for the construction of the Play elements. Neighbors are also a great resource and are great to ask for construction help.

### IMPLEMENTATION / CONSTRUCTION

Construction on a Play elements involves the use of a saw or chainsaw. These elements will take anywhere from a half to full day to complete.

### PLANNING

A few days before starting, call MISS DIG at (800) 482-7171 or 811 to make sure there are not any utilities in the area you want to make an edge design.

Prior to starting construction on a Play edge measure out the space you want to re-design. Use flags, twigs, or string to determine where you want to put Play elements to get a sense of the final constructed design. Look for any uneven ground areas that may need to be accommodated.

### MAINTENANCE

Play elements are low maintenance! Depending on which elements you choose, play edges may require:

1. Touching up of paint
2. Regular mowing of paths and grass areas
3. Watering Plants
4. Occasional fixing of wood elements if something breaks or is worn down.

Play elements should be inspected by the lot owner to ensure everything is still in good condition and safe for kids to enjoy.



# PLAY TYPES



## TIMBER TIME

6x6 wood timber posts and paint can create a very simple or more elaborate play structure for kids and adults alike! With a few posts a balance beam can be made, with more material create a climbing jungle.

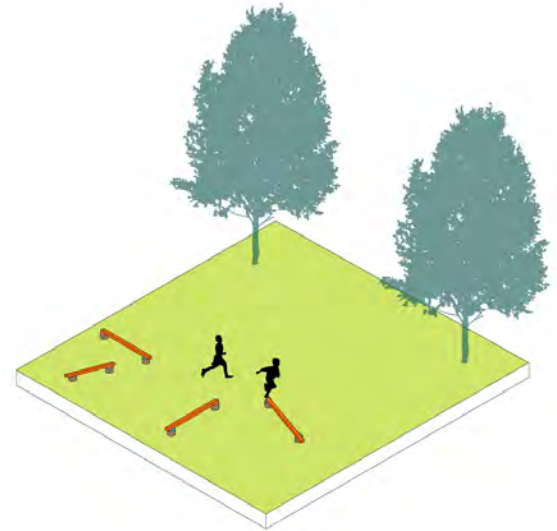

## LOG HOP

Re-purposed logs from cut down trees can be used on to create playful log steppers or simple seats. Using paint makes the logs bright and colorful additions to the lot.



## MOUND PLAY

Mounding and planting earth can be a really simple way to create a play landscape. Mounds can be created by bringing in new dirt or by recycling clean soil that came out of other projects (digging to create a rain garden or excavating areas for paths for example).

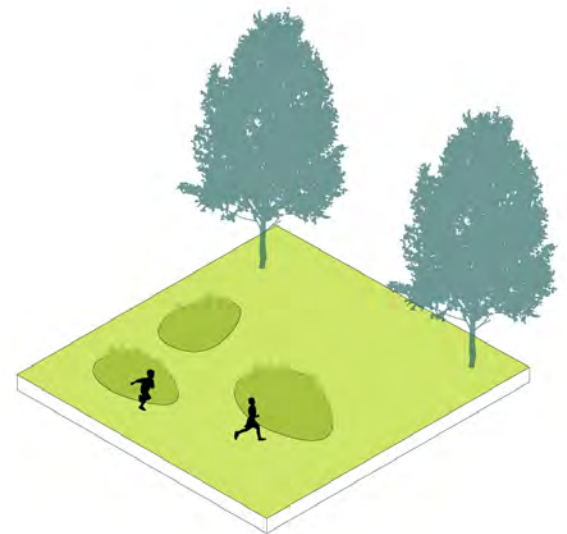

# PLAY TIMBER TIME

## WHAT YOU NEED TO KNOW:

**TIME:** 2-3 days

**LEVEL OF EFFORT:** Medium effort

**NUMBER OF PEOPLE:** 2-3 people

**COST:** \$\$

**EXPERIENCE NEEDED:** Basic measuring skills, basic comfort with power tools

## MATERIALS NEEDED:

- ( 6 ) 8' 6X6 DOUGLAS FIR POSTS
- (4) 12' 6X6 DOUGLAS FIR BEAMS
- (2) 8' 6X6 DOUGLAS FIR BEAMS
- (13) 1" NUT AND BOLT ASSEMBLY (10"L)

## TOOLS NEEDED:

- TAPE MEASURE
- PENCIL
- POWER DRILL
- SOCKET WRENCH SET
- 2.75" HOLE SAW
- 1" DRILL BIT (12"L)
- POST HOLE DIGGER
- LEVEL

**MAINTENANCE:** This is a very low maintenance item. Routinely check all attachments to make sure all fastening is firmly tightened.

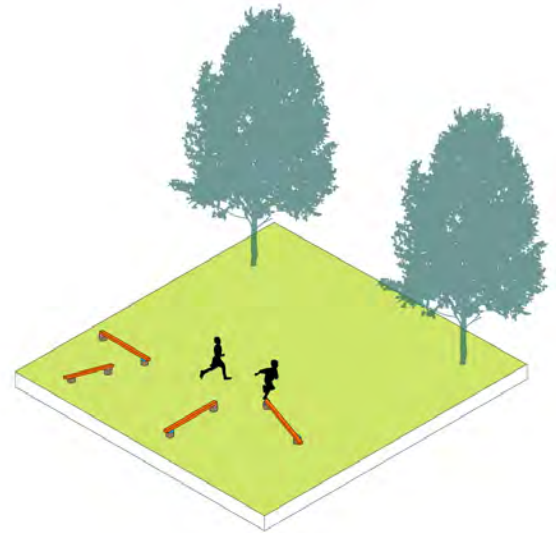

**pairs well with:**  
**Colorful Stencils**  
**Creative Mowing**



# PLAY TIMBER TIME

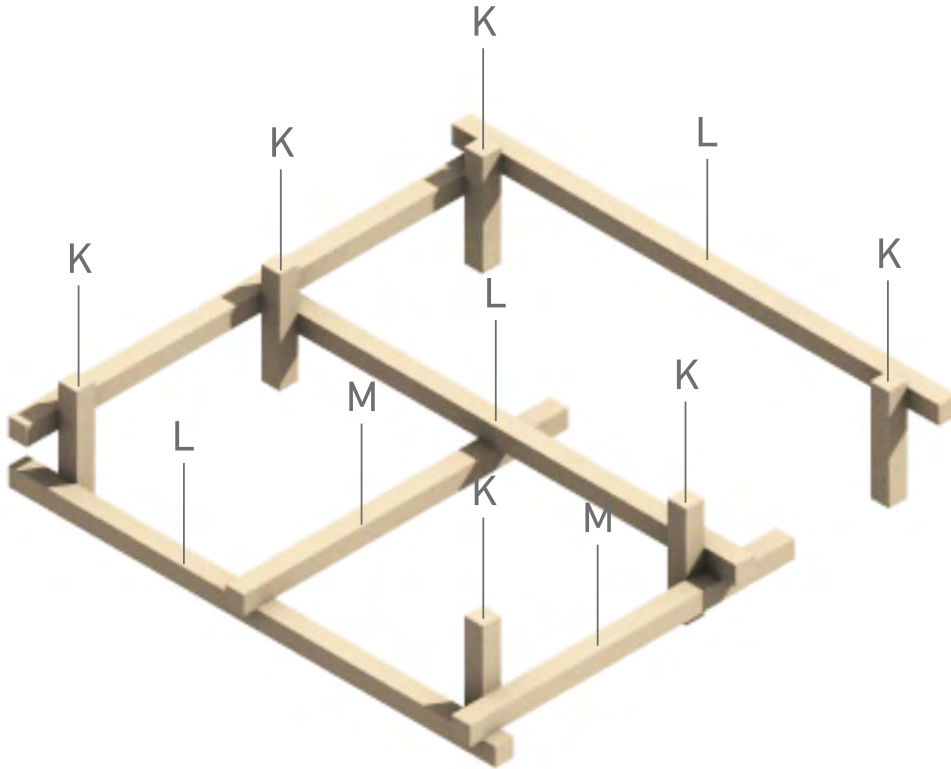

## PARTS

- K - 8' 6X6 DOUGLAS FIR POSTS
- L - 12' 6X6 DOUGLAS FIR BEAMS
- M - 8' 6X6 DOUGLAS FIR BEAMS
- N - 1" NUT AND BOLT ASSEMBLY (10"L)

## MEASURING GUIDE

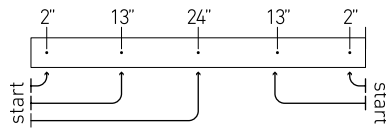

All dimensions are taken from outside edge of piece inward.



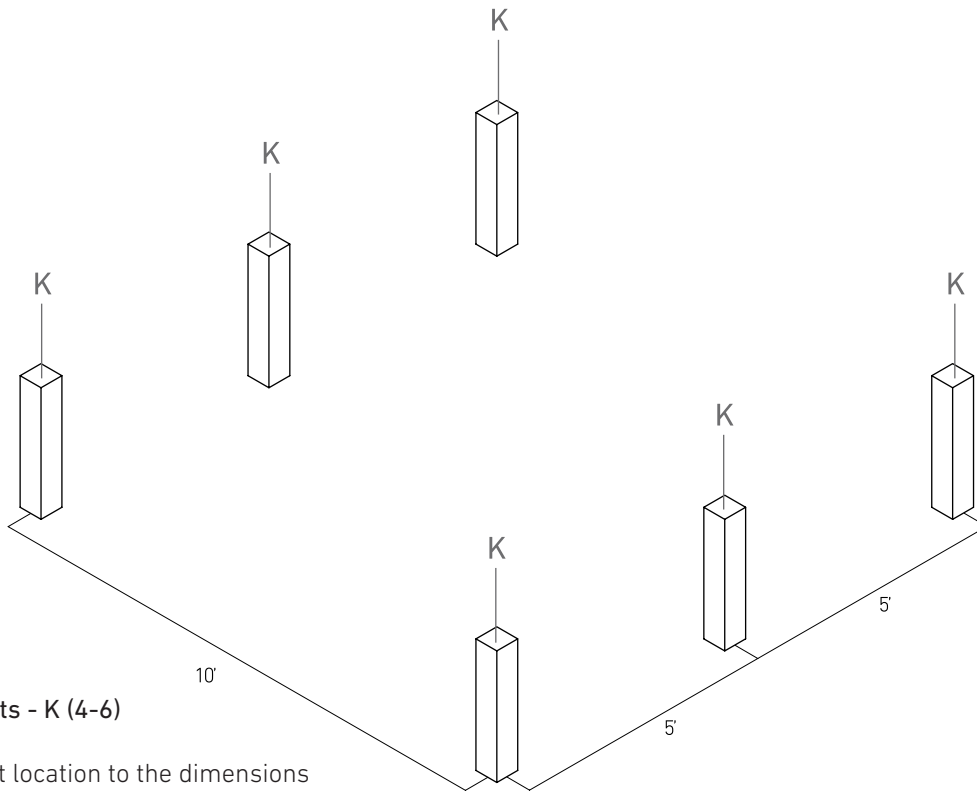

## STEP 01 parts - K (4-6)

Mark out post location to the dimensions shown above. Set posts(K) 4' into the ground using a post hole digger. Level posts and compact soil back into the hole around the post.

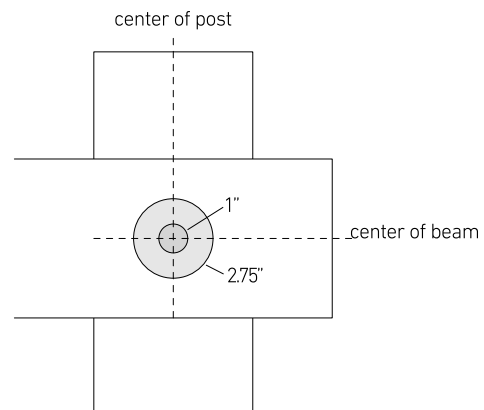
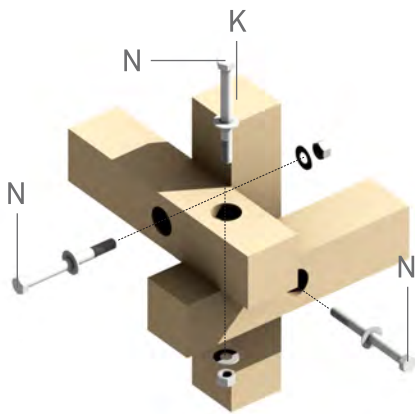

## STEP 02 parts - N (qty varies)

Fasten beams to post with a simple 1" nut and bolt assembly. Each attachment should be pre-drilled before attempting to fasten. Use the Fastening location diagram to layout your attachments.

## FASTENING LOCATIONS

All post and beams should be fastened in center of each member. Two holes need to be drilled for proper attachment. First, drill a 2.75" diameter hole 1" deep using a hole saw bit. Second, using the the drill bit hole from the hole saw, drill a 1" hole through the beam or post.

# PLAY

## LOG HOP

### WHAT YOU NEED TO KNOW:

**TIME:** Half a day

**LEVEL OF EFFORT:** Medium effort

**NUMBER OF PEOPLE:** May need help lifting and cutting stumps

**COST:** \$

**EXPERIENCE NEEDED:** Experience with a chainsaw

### MATERIALS NEEDED:

+ Dead tree logs

+ Paint (optional)

### TOOLS NEEDED:

- TAPE MEASURE

- PENCIL

- CHAINSAW

- SHOVEL

- PAINT BRUSH

**MAINTENANCE:** These stumps are LOW maintenance! They will need to be mowed around when grass gets tall.

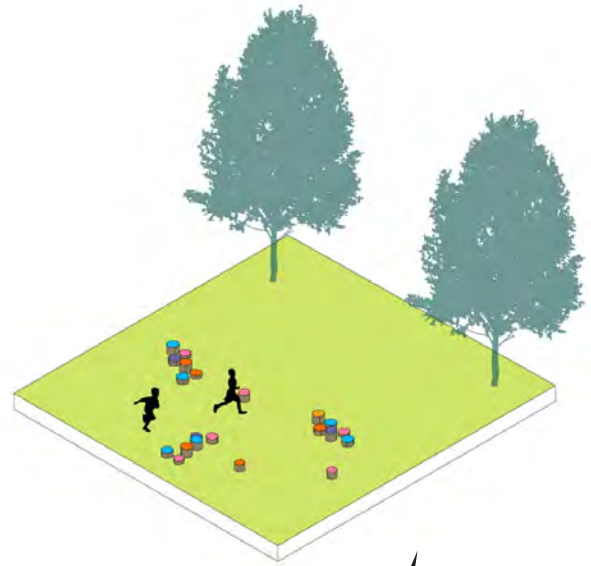

**pairs well with:**  
**Colorful Stencils**  
**Creative Mowing**





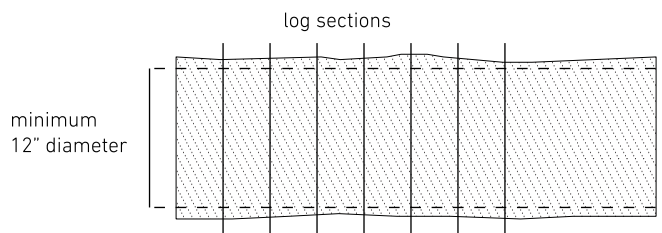
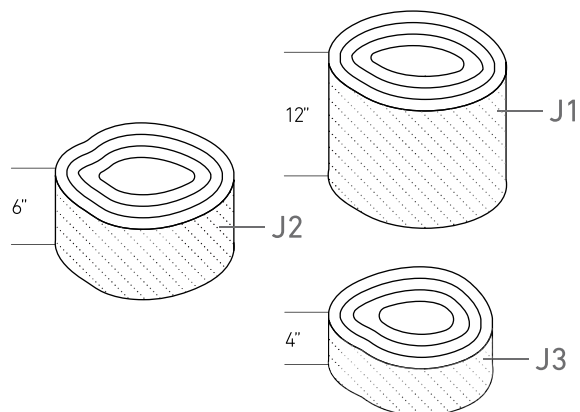

## PARTS

- J1 (MIN 6) - 12" ABOVE GROUND LOG (24" CUT LENGTH)
- J2 (MIN 6) - 6" ABOVE GROUND LOG (12" CUT LENGTH)
- J3 (MIN 6) - 4" ABOVE GROUND LOG (8" CUT LENGTH)
- R (1) 24" REBAR SEGMENT

## TOOLS

- TAPE MEASURE
- PAINT BRUSH
- PENCIL
- DRILL AND 1/2" DRILL BIT
- CHAINSAW
- HAMMER
- SHOVEL

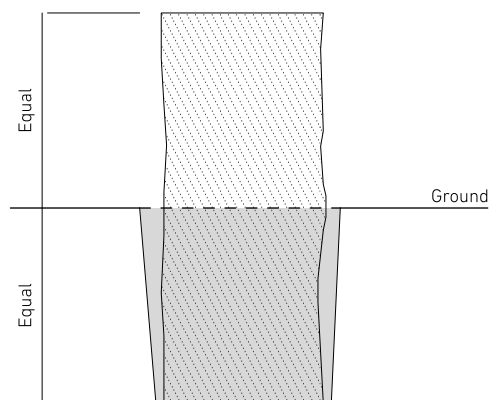

## STEP 02 parts - J1 (6), J2 (6), J3 (6)

Bury half of each of the log sections in the ground. Make sure the bottom of the hole is level and the log section sits upright in the hole. Use the handle end of the shovel to compacted soil back into the hole to secure the log in place.

## STEP 01 parts - J1 (6), J2 (6), J3 (6)

Find fallen or dead trees with a diameter of 12" or greater. Saw tree into J1, J2 and J3 log section. Bark can be left on the log section.

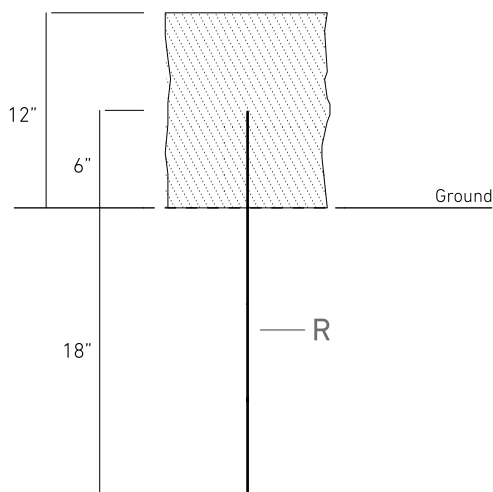

## STEP 02 (ALTERNATIVE) parts - J1 (6)

An alternate for burying the taller 12" logs for stability is to drill a 1/2" dia. hole in the center of the bottom of the log section that is 6" deep into the log section. Embed the 24" rebar section into the ground, leaving 6" exposed above ground and place the log section on top.

# PLAY

## MOUND PLAY

### WHAT YOU NEED TO KNOW:

**TIME:** 1 month  
**LEVEL OF EFFORT:** Medium effort  
**NUMBER OF PEOPLE:** 3-4 people  
**COST:** \$  
**EXPERIENCE NEEDED:** Great for everyone

### MATERIALS NEEDED:

+ No mow turf seed mix

### TOOLS NEEDED:

- TAPE MEASURE
- SHOVEL
- MARKING STAKES

NOTE: THIS JOB CAN BE DONE BY HAND OR WITH THE USE OF SMALL BACKHOE OR SKID-STEER LOADER

**MAINTENANCE:** Play mounds are LOW maintenance!

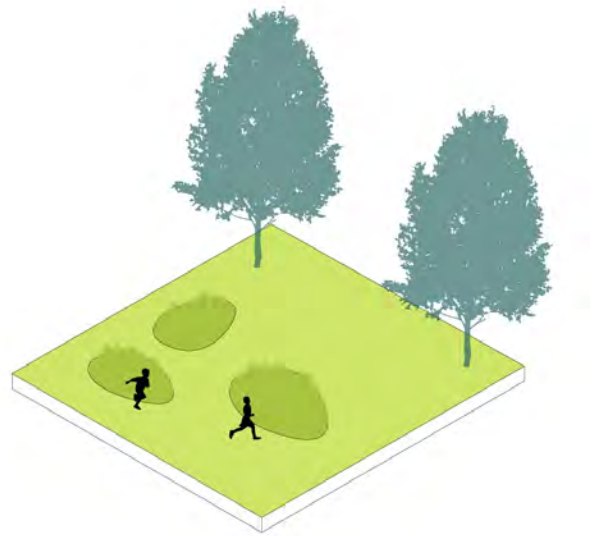

**pairs well with:**  
**Colorful Stencils**  
**Creative Mowing**

### INSTRUCTIONS

1. Roughly stake out the size of the mound(s) you would like to create
2. Decide if the soil for the mounds is coming from on site or from another location.
3. Start moving soil!!
4. Once mound(s) are the size and shape you want, go over with a rake to smooth out the surface of the soil.
5. Follow the instruction that come with the seed mix and apply the mix to the mound(s)
6. Tape off this area until the seed has established (about 3-4 weeks)
7. Water regularly while seed mix is growing
8. After about a month, the mounds should be ready to enjoy!



# PLAY POSSIBILITIES

## **STEPPING STONE HOPSCOTCH**

- + *LABYRINTH PATHS*
- + *CREATIVE MOWING*

Mowing is an art form and can create paths and changing spaces for kids to run along. Try mowing in different patterns around the landscape and see what happens!



## **NO DUMPING PLAY**

- + *PLAY AND ACTIVITY SPACES*
- + *PREVENTS ACCESS TO LOTS VIA CAR*
- + *RECYCLED WOOD, PALETTES, OR LOGS*

Play can be arranged along an edge to form a barrier to the rest of the lot. Not only does this provide active space for kids, it also prevents access to the lot interior to prevent dumping

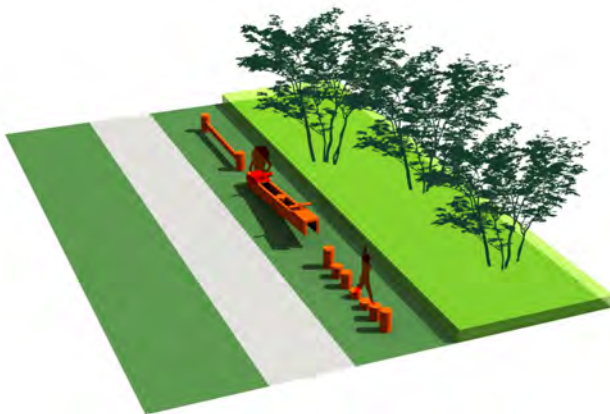



# GATHER

**GATHER** includes the designed elements and surrounding landscape that make up a gathering space. Gather pairs well with Garden, Ground, and Identity to create inviting communal spaces. The modular design of the gathering bench allows for expanded seating depending on the intended use. This section will tell you how to:

- + *select the right play features for your site*
- + *construct the primary play features*
- + *incorporate PLAY with other edge typologies*

## GATHER FEATURES

### A PLACE TO COME TOGETHER

Gather edges are spaces to sit for a moment, to have a conversation, to rest, or to read. Gather edges can be designed for one or two people or for larger groups. It is up to you! Gather edges can be narrow or wide and can be moved around depending on what people want to do there.

### BUILDING A GATHER EDGE

Gather edge elements, such as the bench, can be combined with interesting mowing or Ground elements (see page 80!) to form interesting spaces for the community to visit. The bench design is flexible and can be combined in many ways. Don't be afraid to test out different layouts and see what works best for your lot.

## CONSIDERATIONS

### RESOURCES

There are a number of construction how-to resources online that can serve as a guide for the construction of the Gather elements. Neighbors are also a great resource and are great to ask for construction help.

See the end of the chapter for alternate layout ideas ranging from SMALL to LARGE group gathering areas.

### IMPLEMENTATION / CONSTRUCTION

Construction on a Gather or gathering space will require a few people. The final benches are heavy, so have help to lift or move them. Creating a gather space could take a full weekend.

### PLANNING

It is important to assess the location of a Gather edge for the comfort of those sitting there. Is there a tree that might provide shade in the summer months? Is it quiet enough to hold a conversation?

Prior to starting construction of a Gather edge measure out the space you want to re-design. Use flags, twigs, or string to determine where you want to put benches to get a sense of the final constructed design. Test a few options out! Look for any un-even ground; this will need to be leveled out for benches to sit soundly on the ground.

### MAINTENANCE

Gather elements are low maintenance! Over time, Benches and seating elements may need:

1. Touching up of paint
2. Regular mowing of paths and grass areas
3. Watering Plants
4. Occasional fixing of wood elements if something breaks or is worn down.
5. Clearing or repairing of any GROUND designs paired with a bench.

Benches will stay in better condition if they are taken in and stored over the winter.



# GATHER TYPES



## SMALL GATHER

A single bench can transform an edge into a space. Any single lot can accommodate a bench with the help of GARDEN and GROUND.

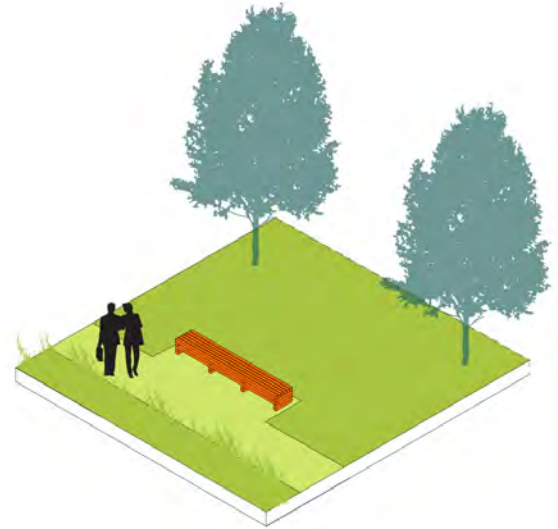

## MEDIUM GATHER

A lot for more cleared space can accommodate a larger bench. This construction will likely require more time and hands to help!



## LARGE GATHER

For a multi-lot site, a larger seating area with multiple benches can create an inviting park-like space for the community to gather. This will require plenty of time, hands, and resources! recycled concrete from an old sidewalk, or found natural stones can be a cheaper and less formal option to create ground surfaces.



# GATHER

## SMALL GATHER

### WHAT YOU NEED TO KNOW:

**HOURS:** This could take two days

**LEVEL OF EFFORT:** High effort

**NUMBER OF PEOPLE:** You may need help lifting lumber, cutting it, and moving the final benches

**COST:** \$\$\$\$

**EXPERIENCE NEEDED:** Experience cutting wood, painting, and using tools

### MATERIALS NEEDED:

- + (8) - 10' 4X4 DOUGLAS FIR
- + (12) - 23.5" 4X4 DOUGLAS FIR
- + (3) - 16.5" 4X4 DOUGLAS FIR
- + (64) - #12 EXTERIOR SCREW (5"-6"L)
- + (1G) - CLEAR WOOD PROTECTOR

### TOOLS NEEDED:

- TAPE MEASURE
- PENCIL
- POWER DRILL
- DRILL AND FASTENING BITS
- CIRCULAR SAW
- PAINT BRUSH

**MAINTENANCE:** Gather elements require touch-up painting and should be taken in for the winter months to protect the wood.

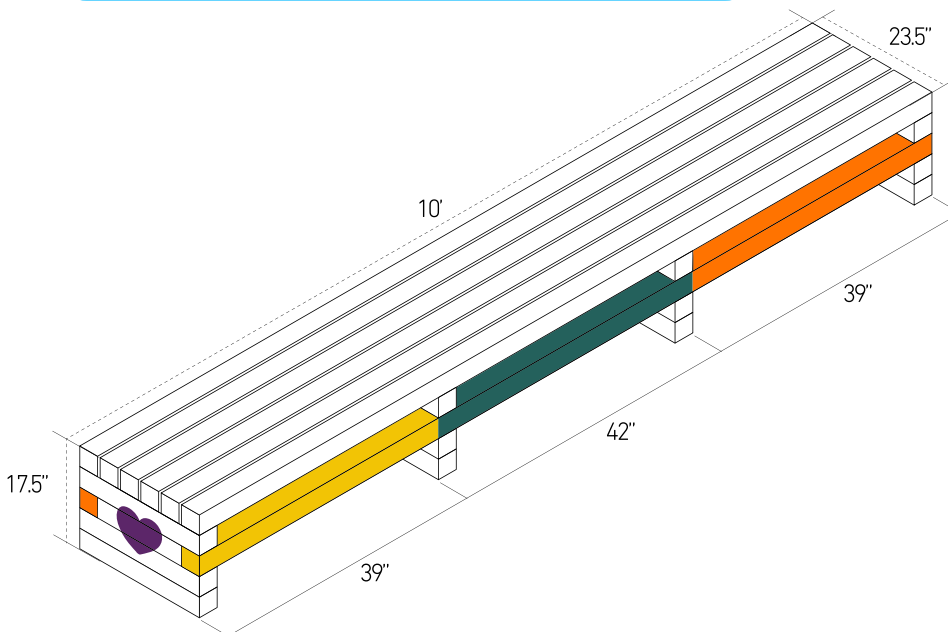
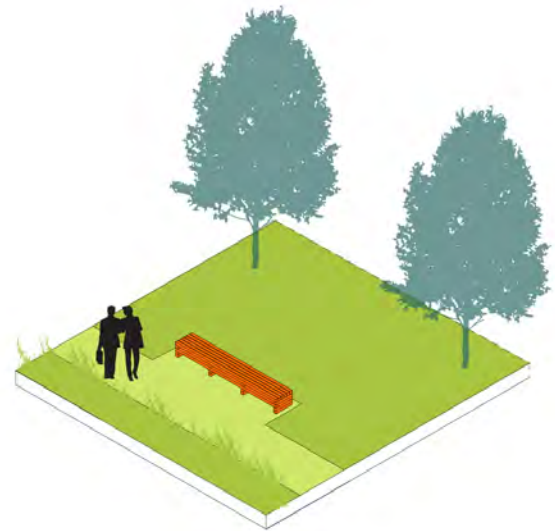

### PARTS

- A (8) - 10' 4X4 DOUGLAS FIR
- B (12) - 23.5" 4X4 DOUGLAS FIR
- C (3) - 16.5" 4X4 DOUGLAS FIR
- F (64) - #12 EXTERIOR SCREW (5"-6"L)
- P (1G) - SW 6496 OCEANSIDE
- S (1G) - CLEAR WOOD PROTECTOR

### MEASURING GUIDE

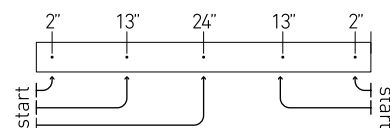

All dimensions are taken from outside edge of piece inward.



# GATHER

## SMALL GATHER

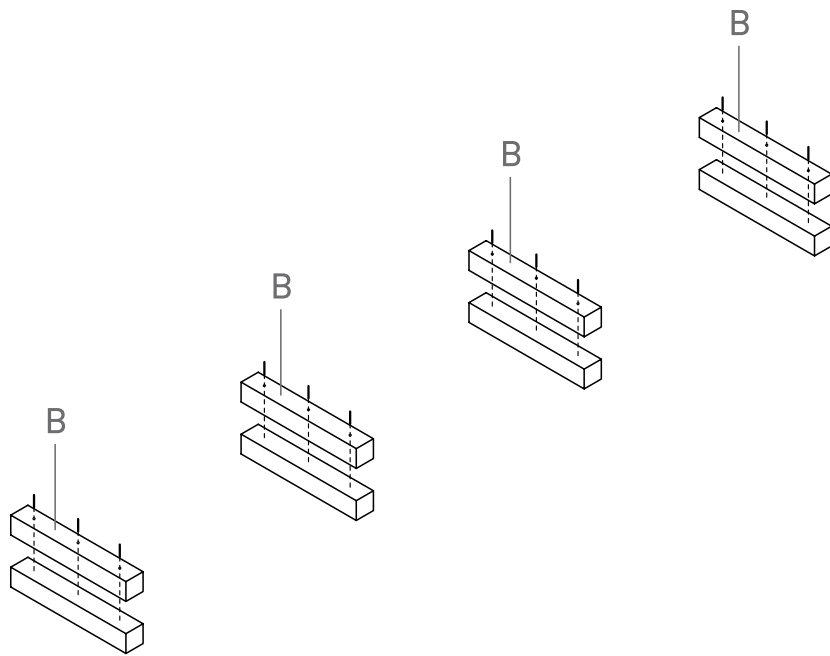

### STEP 01 parts - B (8)

Fasten two B pieces together. Repeat 3 times to create a total of 4 bench bases.

### FASTENING LOCATIONS

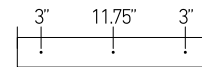

All dimensions are taken from outside edge of piece inward. See dimensioning diagram.

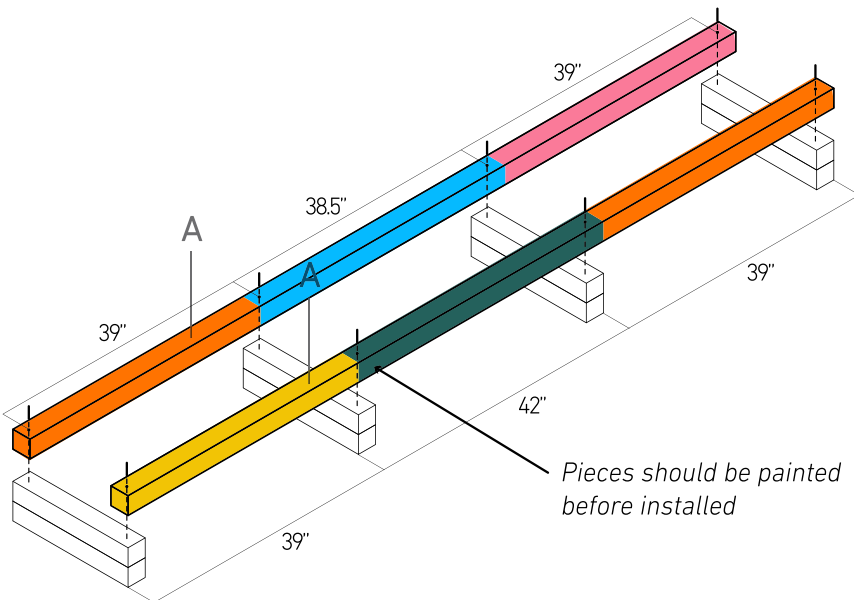

### STEP 02 parts - A (2), P

Using two A pieces, fasten the bench bases together. Layout pieces and pre-mark hole locations. Bench bases should next be center centered on mounting holes.

### FASTENING LOCATIONS

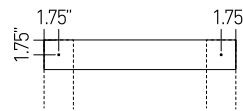

All dimensions are taken from outside edge of piece inward. See dimensioning diagram.





# GATHER

## SMALL GATHER

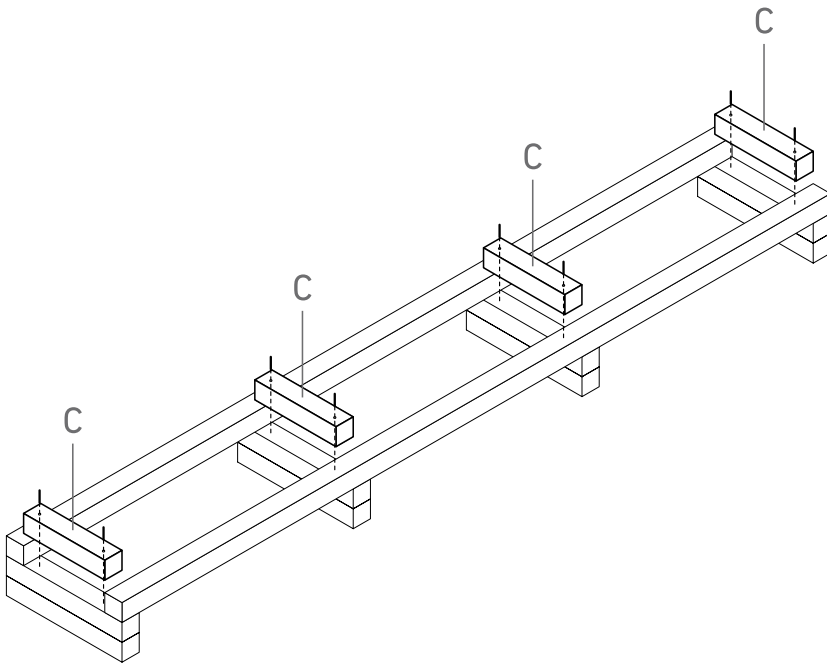

### STEP 03 parts - C (4)

Fasten one C piece to the bench bases between each of the four cross braces.

### FASTENING LOCATIONS

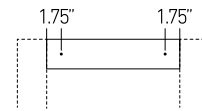

All dimensions are taken from outside edge of piece inward. See dimensioning diagram.

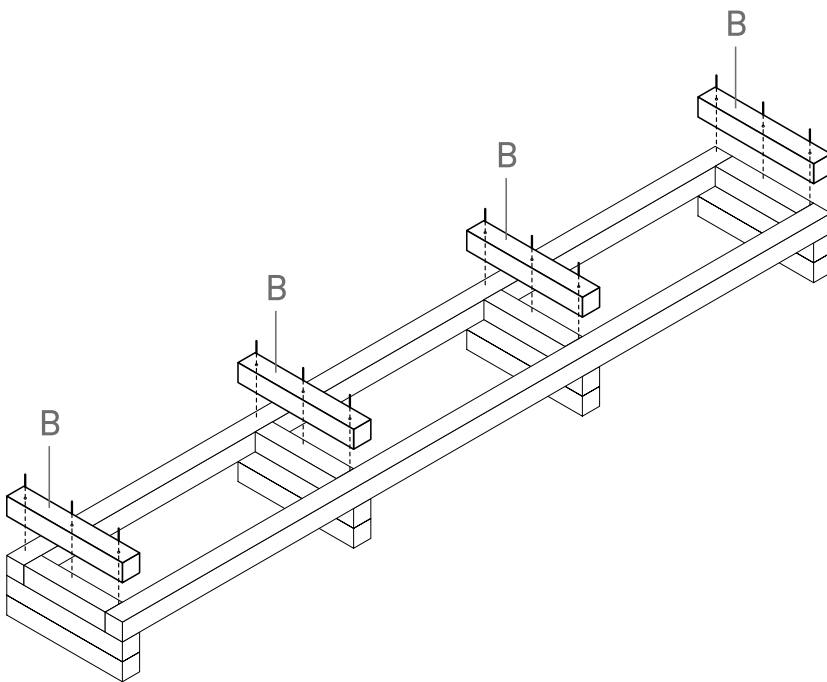

### STEP 04 parts - B (4)

Fasten four B pieces on top of the previously installed C pieces in Step 03. Pieces should be centered on bench bases, so the side face is completely flush.

### FASTENING LOCATIONS

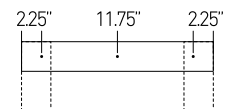

All dimensions are taken from outside edge of piece inward. See dimensioning diagram.



# GATHER

## SMALL GATHER

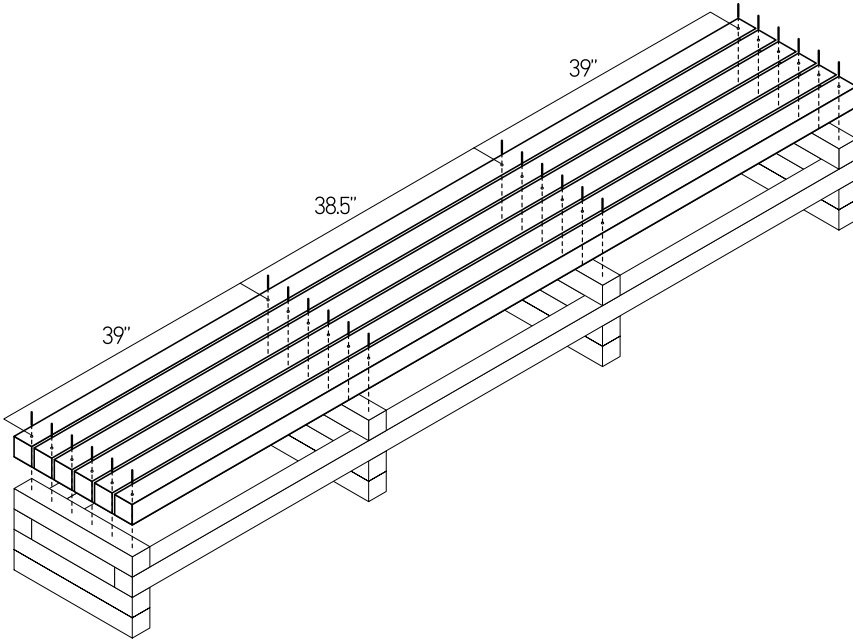

### STEP 05 parts - A (6)

Fasten A pieces to each of the bench bases to create the top of the bench. Lay-out pieces and pre-mark hole locations.

### FASTENING LOCATIONS

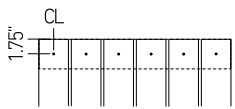

Use a 1/2" spacer when layouting and fastening pieces to base

All dimensions are taken from outside edge of piece inward. See dimensioning diagram.

### STEP 06 parts - S

Once the bench is complete you can paint and seal the bench. Follow instructions on wood sealant container to apply a coat over all non painted surfaces. Use stencils to brand benches once sealant has dried.



# GATHER POSSIBILITIES

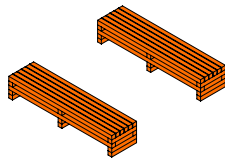

## SMALL GROUP GATHER

Great for creating a more intimate space for a family or small group of friends to meet.

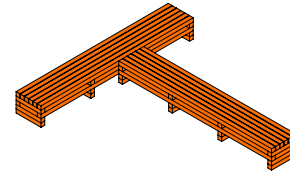

## T-BENCH

Can accommodate different small groups of people.

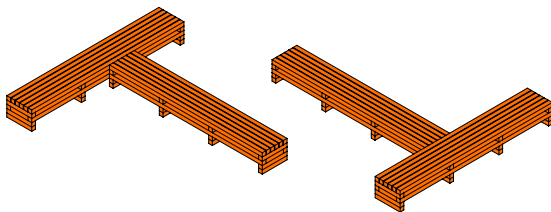

## COMMUNITY GATHER

Accommodates larger groups for a party or a large community gather.

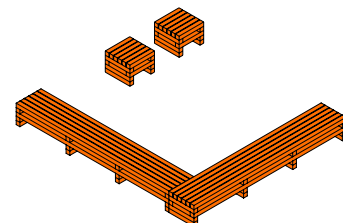

## FLEXIBLE GATHER

Small movable benches create flexible gathering space.

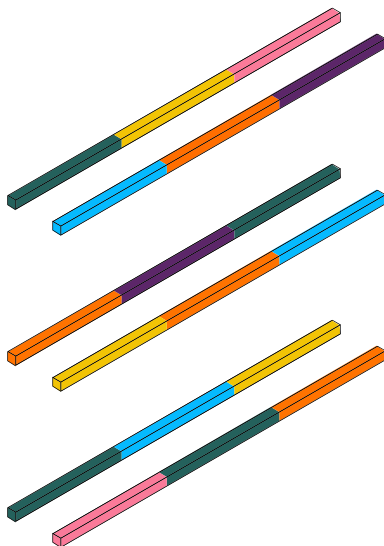

## COLOR COMBINATIONS

Use the provided color palette to create a playful bench!





# EXCHANGE

**EXCHANGE** includes designed elements: seating, and a stage, that could be added to our lot to support community commerce and entrepreneurship. **EXCHANGE** lots work well with **GROUND** designs, with added planting, and can be made more robust by adding an additional **GATHER** bench to accommodate more people.

**This section will tell you how to:**

- + *select the right exchange elements***
- + *construct the exchange designs***
- + *connect to other edge designs***

## EXCHANGE FEATURES

### A PLACE TO SHARE GOODS OR IDEAS

Exchange lots are places to perform a poem, to set up wracks of things to sell. They are places to celebrate the community of East Davison. Exchange designs can be combined with any other design in this chapter to create a destination in the community.

### BUILDING AN EXCHANGE EDGE

Exchange edge construction will involve sourcing lumber or palettes, and may take a few days to fully complete. Exchange edges can be flexed to suit the lot they are being installed on, from more to less narrow. Exchange edges can be as simple as a table for a few people all the way to a performance space for many community members to come together around.

## CONSIDERATIONS

### RESOURCES

See the end of the chapter for alternate layout ideas to create various forms of Exchange.

Look to the other typologies such as Ground and Gather for ideas to add to Exchange to create a rich space on your lot.

### PLANNING

Reach out to your neighbors and the community if you wish to create opportunities for Exchange on your lot. You will want collective guidance on the goals for this space as it will be a shared resource. You will also want to find help in constructing some of these features so that the process can be faster and fun!

Planning is key for this typology. Source your materials locally and be prepared to transport the lumber yourself with a truck or find a hardware store that can deliver materials.

Refer to the Neighborhood Quilt Plan to see where the community has said Exchange locations make the most sense.

### IMPLEMENTATION / CONSTRUCTION

Construction will require a few people and at least a weekend to build. Have fun by sharing this process with your neighbors!

### MAINTENANCE

Exchange elements are low maintenance! Over time, Stages and seating elements may need:

1. Touching up of paint
2. Regular mowing of paths and grass areas
3. Watering Plants
4. Occasional fixing of wood elements if something breaks or is worn down.
5. Clearing or repairing of any Ground designs paired with a bench.

Benches and stages will stay in better condition if they are taken in and stored over the winter or covered with tarp.



# EXCHANGE TYPES



## COMMUNITY TABLE

Creative re-use of pallets and the Cube seats can create a community table space to come together for conversations and meals.

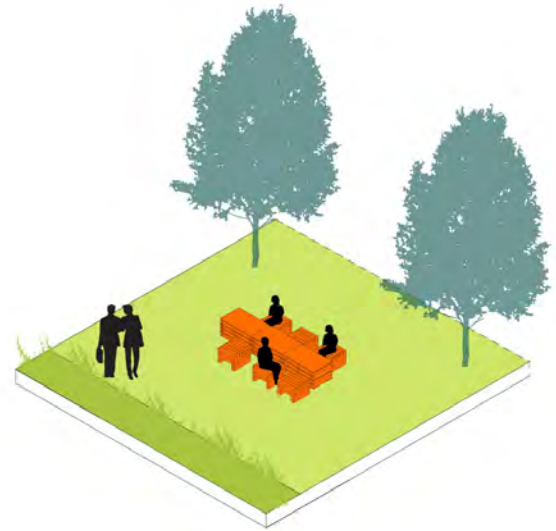

## COMMUNITY STAGE

A simple stage and seating can create a venue for neighborhood performances and presentations. Getting creative with glow-in-the-dark tape can add nighttime interest!



## MARKET STALLS

Pallets can be reused to form a place for exchanging goods. Tents can be rented to provide shelter during community events while elements such as a kiosk (above) can offer 'storefront' space.



# EXCHANGE

## COMMUNITY TABLE | Cube Bench

### WHAT YOU NEED TO KNOW:

**TIME:** 1 month  
**LEVEL OF EFFORT:** High effort  
**NUMBER OF PEOPLE:** 3-4 people  
**COST:** \$\$\$  
**EXPERIENCE NEEDED:** Experience cutting wood, painting, and using tools

### MATERIALS NEEDED:

B (14) - 23.5" 4X4 DOUGLAS FIR  
 C (2) - 16.5" 4X4 DOUGLAS FIR  
 F (32) - #12 EXTERIOR SCREW (5"-6"L)  
 P (1G) - SW 9176 DRESS BLUE  
 S (1G) - CABOT® CLEAR WOOD PROTECTOR

**MAINTENANCE:** Exchange elements are low maintenance once constructed.

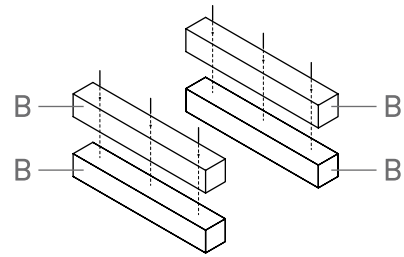

### STEP 01 parts - B (4), F (6)

Fasten two B pieces together.  
 Repeat once to create the seat base.

### FASTENING LOCATIONS

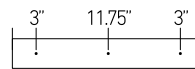

All dimensions are taken from outside edge of piece inward. See dimensioning diagram.

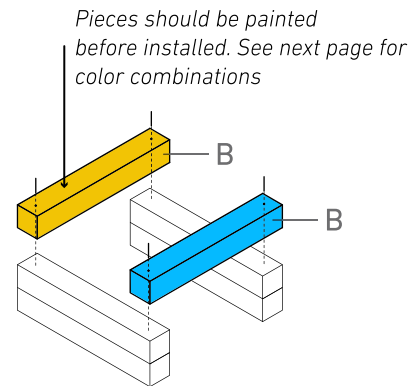
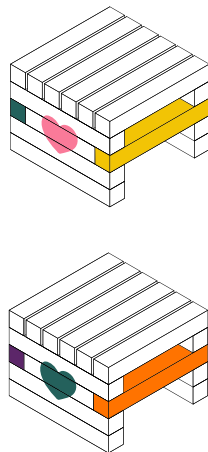
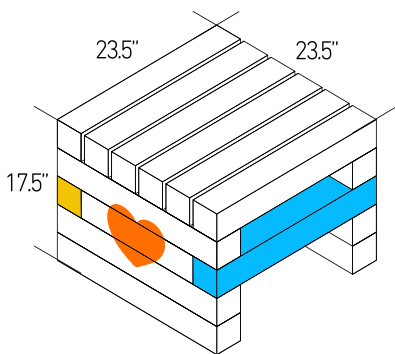

### STEP 02 parts - B (2), F (4), P

Using two B pieces, fasten the seat base together. Layout pieces and pre-mark hole locations.

### FASTENING LOCATIONS

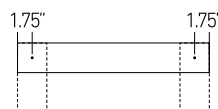

All dimensions are taken from outside edge of piece inward. See dimensioning diagram.

### MEASURING GUIDE

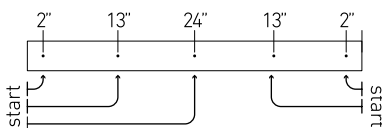

All dimensions are taken from outside edge of piece inward.



# EXCHANGE

## COMMUNITY TABLE | Cube Bench

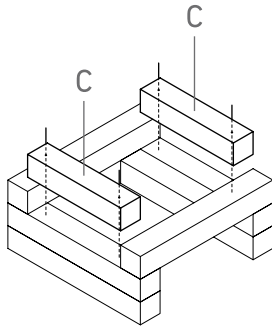

### STEP 03 parts - C (2), F (4))

Fasten two C pieces between the cross braces, one at each cross brace.

#### FASTENING LOCATIONS

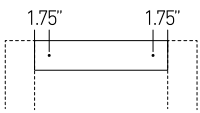

All dimensions are taken from outside edge of piece inward. See dimensioning diagram.

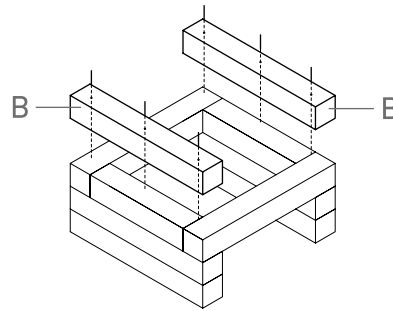

### STEP 04 parts - B (2), F (6)

Fasten two B pieces on top of the previously installed C pieces.

#### FASTENING LOCATIONS

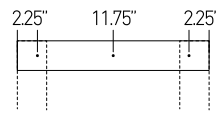

All dimensions are taken from outside edge of piece inward. See dimensioning diagram.

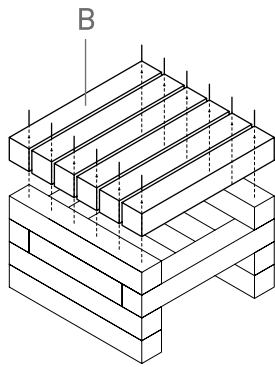

### STEP 05 parts - B (6), F (12)

Using two B pieces, fasten the seat bases together.

#### FASTENING LOCATIONS

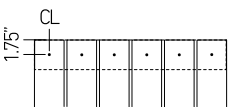

All dimensions are taken from outside edge of piece inward. See dimensioning diagram.

Use a 1/2" spacer when layouting and fastening pieces to base

### STEP 06 parts - S

Once bench is complete. Follow instructions on wood sealant container to apply a coat over all non painted surfaces. Use stencils to brand benches once sealant has dried.





# EXCHANGE

## COMMUNITY TABLE | Table

### MATERIALS NEEDED:

- B (14) - 23.5" 4X4 DOUGLAS FIR
- C (2) - 16.5" 4X4 DOUGLAS FIR
- F (32) - #12 EXTERIOR SCREW (5"-6"L)
- P (1G) - SW 9176 DRESS BLUE
- S (1G) - CABOT® CLEAR WOOD PROTECTOR

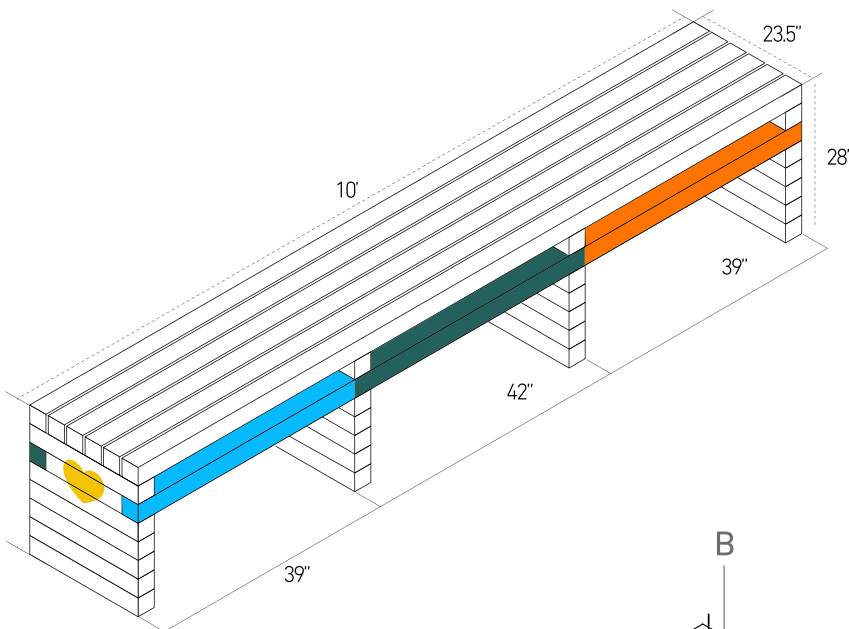

### MEASURING GUIDE

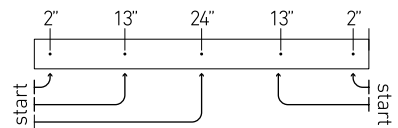

All dimensions are taken from outside edge of piece inward.

### STEP 01 parts - B (20)

Fasten five B pieces together. Repeat 3 times to create a total of 4 table legs.

### FASTENING LOCATIONS

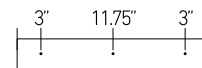

All dimensions are taken from outside edge of piece inward. See dimensioning diagram.

### STEP 02-05 pg 56 - 58

For steps 02 through 05 refer to small gather bench construction found on page 56.

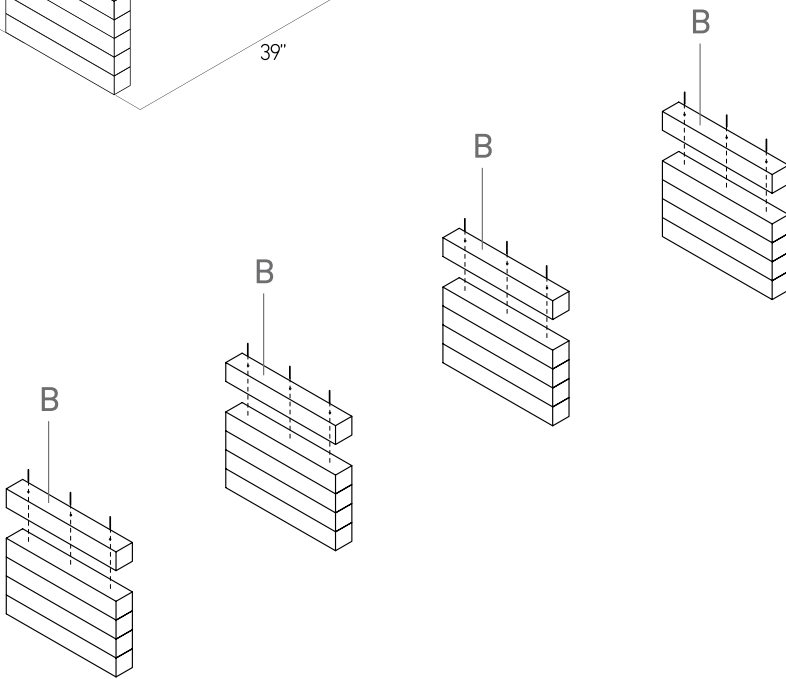

# EXCHANGE COMMUNITY STAGE

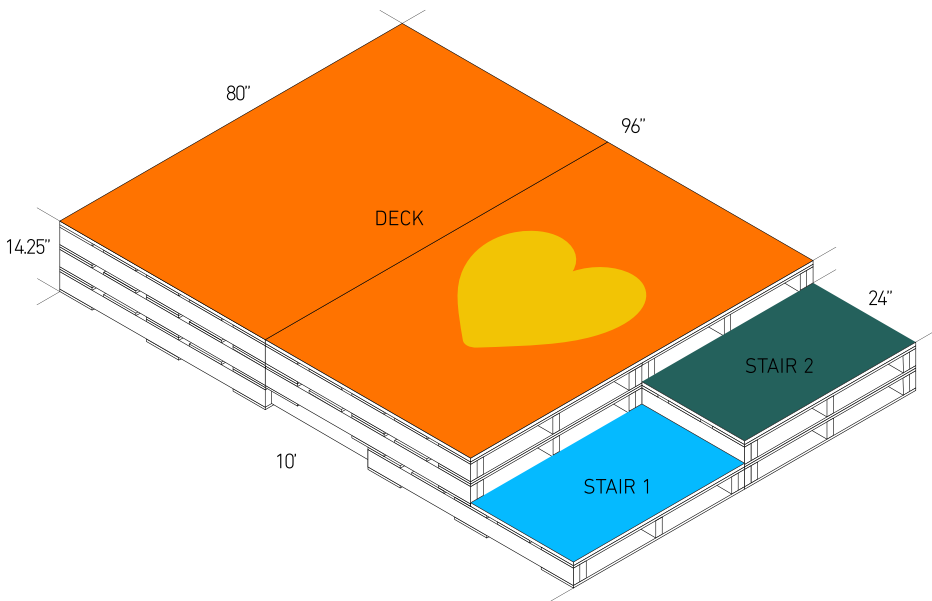

## PARTS

- G (12) - 40X48 RECLAIMED PALLET
- H (2) - 48"X80" 3/4" AC2 TREATED PLYWOOD
- I (2) - 24"X40" 3/4" AC2 TREATED PLYWOOD
- D (6) - 2X4 8' DOUGLAS FIR
- E (6) - 2X4 10' DOUGLAS FIR
- F (246) - #9 EXTERIOR SCREW (2.5" L)
- P (1G) - SW6886 INVIGORATE ORANGE OR SW6965 HYPER BLUE

## MEASURING GUIDE

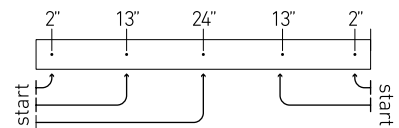

All dimensions are taken from outside edge of piece inward.

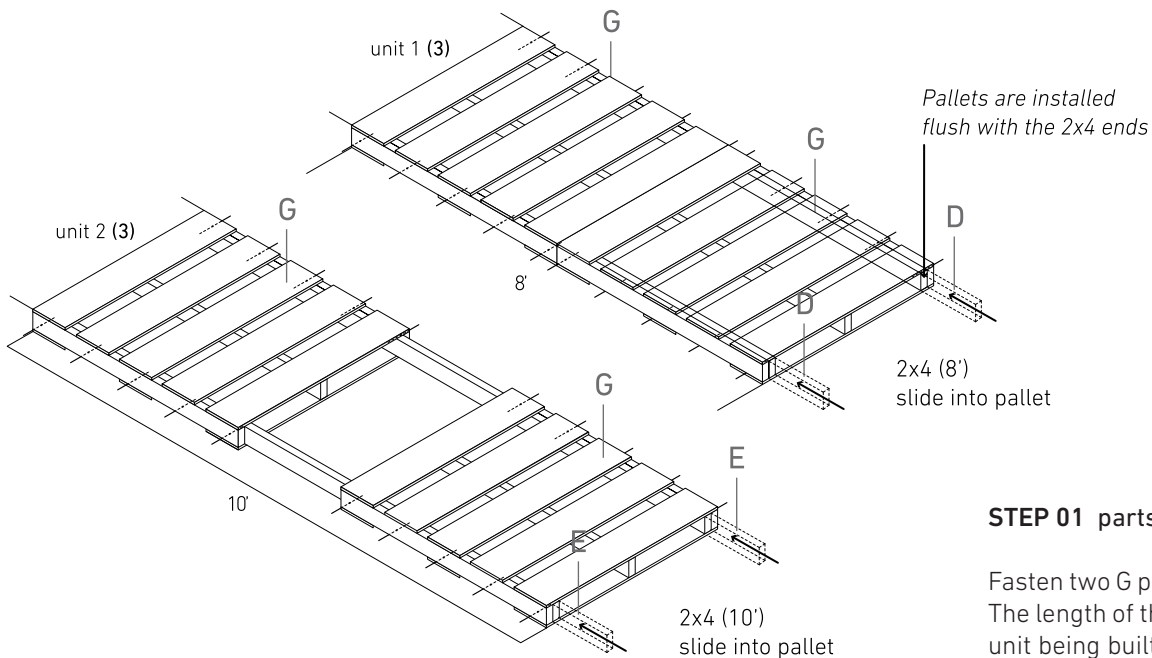

## STEP 01 parts - G(12), D(8), E(4), F(120)

Fasten two G pieces together using 2x4's. The length of the 2x4 is dependent on the unit being built. A total of (4) unit 1's and (2) unit 2's should be assembled.

### FASTENING LOCATIONS

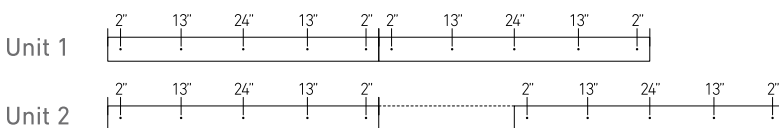

All dimensions are taken from outside edge of piece inward. See dimensioning diagram.



# EXCHANGE COMMUNITY STAGE

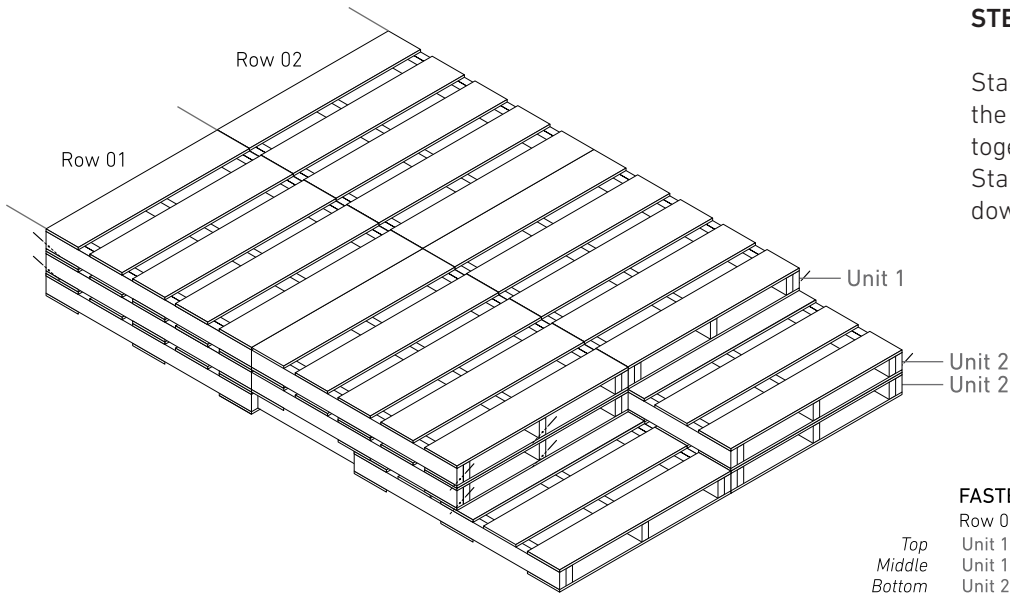

## STEP 02 parts - F (48)

Stack units into two rows based off the diagram below. Fasten each unit together with a screw in each corner. Start low on the unit and angle the screw down towards the unit below.

### FASTENING LOCATIONS

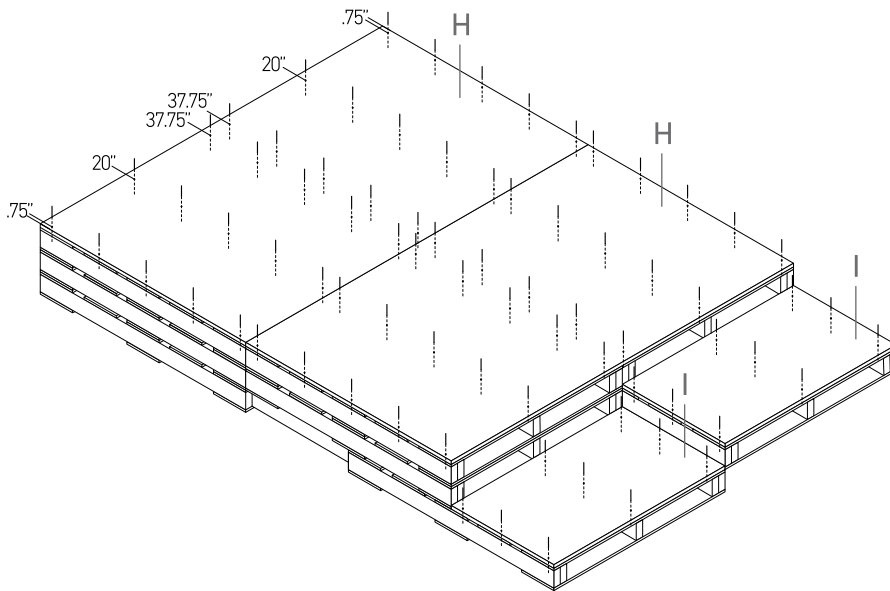

## STEP 03 parts - H (2), I (2), F (78)

Fasten parts B and C to the top of each row. Plywood is fastened perpendicular to the rows for a solid platform.

### FASTENING LOCATIONS

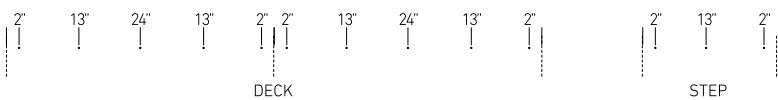

All dimensions are taken from outside edge of piece inward. See measuring guide diagram.

## STEP 04 parts - P

Paint plywood surfaces and set aside to dry. Follow instructions on paint container to apply a coat on all exposed surfaces.

### COLOR COMBINATIONS

- SW 6794 Flyaway
- SW 6884 Obstinate Orange
- SW 6903 Cheerful
- SW 6482 Cape Verde



# EXCHANGE POSSIBILITIES

pairs well with:  
**GATHER benches**  
**IDENTITY stencils**

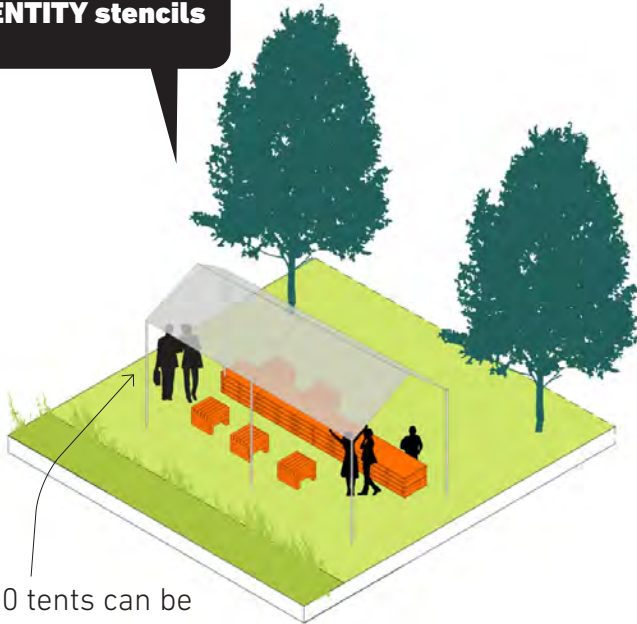

10x10 tents can be rented to provide shelter for community events.

## COMMUNITY TABLE

- + EASY SET UP
- + RENTED TENTS CAN ADD SHELTER
- + CAN BE USED FOR MANY TYPES OF EVENTS

Arranging Exchange elements in new ways provides opportunities for additional kinds of community gathering. Tents can be rented and placed together to create space for picnics, weddings and special events, festivals, and outdoor markets!



# EXCHANGE POSSIBILITIES

## **SEED EXCHANGE**

- + EASY INSTALL
- + EDV BRANDED
- + SEEDS THAT REFLECT COMMUNITY CULTURE

Small boxes are a great way to share items with each other. A SEED EXCHANGE is a great way to create access to the tools needed to add beauty to a lot.

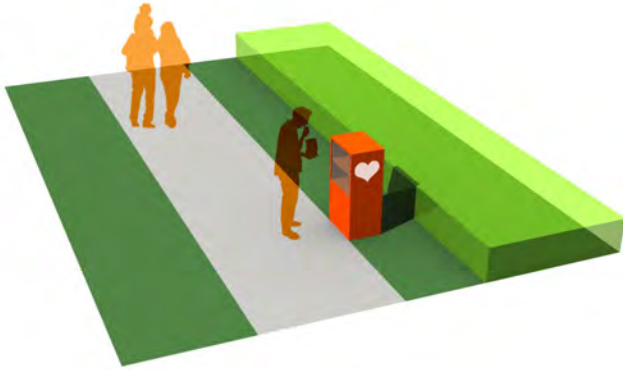

## **COMMERCIAL LAWN**

- + PALETTES OR OTHER RECYCLED WOOD
- + 5-10 PERSON CAPACITY
- + BRANDED COLORS OR LOGO STENCILED

Interesting mowing patterns, such as the circle shown here, are a great way to form a space to share ideas, goods, or gather for an outdoor class.

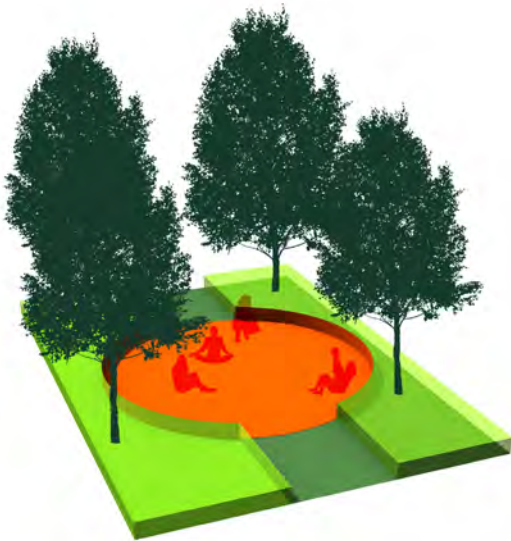



**04**

**GLOSSARY**

**EDGING  
FRAMEWORK  
PLAN**

# MATERIALS + TOOL LIBRARY

## **DOUGLAS FIR SQUARE TIMBERS**

Douglas Fir timbers are available at most lumbar retail stores. Douglas fir is durable and long-lasting. Ask about cutting services where you purchase it!

## **DOUGLAS FIR BOARDS**

Douglas Fir boards are durable and do not require a sealant. These boards are versatile.

## **WOOD PALETTE**

Palettes are an affordable material option. They can often be purchased for little or no money. Palettes can be deconstructed to recycle lumber as well.

## **STEPPERS / PAVING MATERIAL**

Steppers / Paving Materials come in many shapes and sizes. Pick a paver that is a standard size for easier installation or a recycled material such as concrete or stone for a more free-form look.

## **2" MINUS AGGREGATE**

Every Ground edge design will need aggregate so it can properly drain. Ask for 2" MINUS, which means it has been cleaned.

## **SAND**

Sand is what will be the bottom of your GROUND edges. It provides a stable base for stepper/paving material.

## **PAINT**

Bring the paint codes listed on page 125 to find colors that are a part of the East Davison Village color palette!







***Douglas fir square timbers***



***Douglas fir boards***



***Wood pallet***



***Square Stepper***

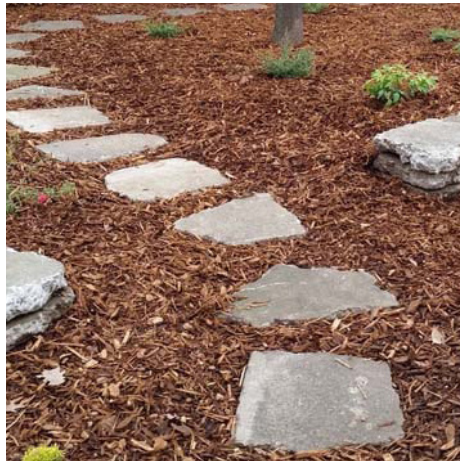

***Recycled Concrete Steppers***

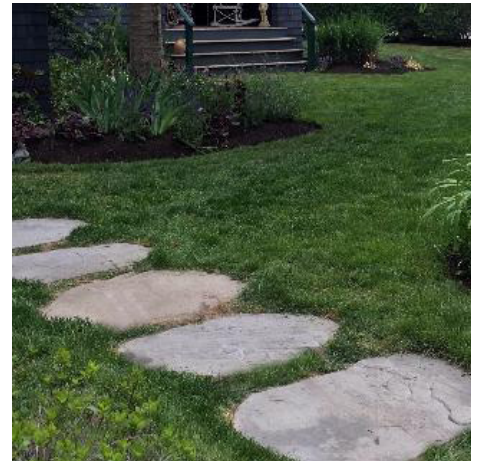

***Natural Stone Steppers***



***Sand***



***2" Minus aggregate***

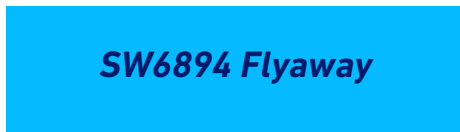

***SW6894 Flyaway***



***SW6903 Cheerful***



***SW 6832 Impulsive Purple***

***Sherwin-Williams Paint***



***SW6886 Invigorate Orange***

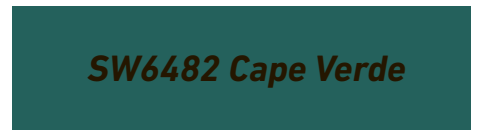

***SW6482 Cape Verde***

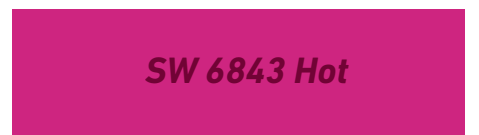

***SW 6843 Hot***

***Sherwin-Williams Paint***



# TERMS + DEFINITIONS

## RELEVANT PLANNING TERMS

### **DLBA / Detroit Land Bank Authority**

The Detroit Land Bank Authority's mission is to return the city's blighted and vacant properties to productive use. The DLBA owns thousands of vacant lots across the City of Detroit.

### **DLBA / Land Reuse Programs**

To establish more land ownership opportunities for residents, the DLBA provides land reuse strategies and vacant land sales programs. See (<https://buildingdetroit.org/land-reuse-programs/>) for more information.

### **Davison/Campau/Banglatown Neighborhood Framework Plan - Open Space Network**

The Davison/Campau/Banglatown Neighborhood Framework Plan Set the following goals for a proposed network of green spaces:

- Strengthen existing park facilities and add new amenities that cater to families and nearby residents
- Improve access to Jayne Field by adding new gateways and by improving internal path networks
- Use vacant lots to create new community green spaces
- Encourage and reward community land stewardship

### **Setback**

The minimum distance which a building or other structure on your lot must be set back from a street or road.

### **Zoning Ordinance**

A rule that defines how property in specific areas or zones can be used. See page 34 for instructions on how to ensure your lot idea meets zoning codes.

## KEY CONCEPTS

### **Cues to Care**

A phrase used to describe features of a landscape that indicate it is taken care of. For example: a mowed lot is a cue to others that someone cares about this space.

### **Disturbance-Adapted Ecology**

Ecological systems that have become used to disruptions in their natural environment from human or natural forces. These ecological communities shift to work in their new conditions.

### **Edge**

Edges are the outermost areas of a lot. They are the boundary along the street, the alley, or the sides of your property neighboring other lots.

### **Lot**

Your lot is defined by the four edges of the property line.

### **Management**

Management is a process of working with what already exists on your lot. Existing vegetation, large trees, and invasive species all require management.

### **Maintenance**

Maintenance is the ongoing care of spaces you have created on your lot.

### **Places of Promise**

The community identified "places of promise", or important landmarks that already exist or are coming in the future, that can serve as anchors for improvements.

### **Typology**

A typology refers to an individual edge TYPE.



**Quilt**

A neighborhood “quilt” suggests that as edge improvements accumulate throughout the neighborhood over time, they create a resilient blanket of patches, seams, knots, and stitches.

**TECHNIQUES + CONSTRUCTION TERMS****Creative Mowing**

Mowing that is not just cutting the whole lot. Creating patterns or paths with your lawnmower is creative mowing.

**Pruning**

Pruning involves the selective removal of certain parts of a plant, such as branches, buds, or roots. Pruning can be done to influence a plant's growing pattern or to improve plant health.

**Soil Amendment**

Soil amendments or soil conditioners improve the physical nature of soil, adding nutrients into existing soils. They reduce compaction, aerating the soil to allow water and nutrients to more easily move through it and reach plant roots.

**PLANT TERMS****Allee**

Aligning trees in a straight line along a path or street.

**Beauty Strip**

A strip of planting along a lot edge to provide aesthetic value as well as prevent access for dumping.

**Bosque**

A cluster or group of trees intentionally laid out in more or less formal pattern.

**Invasive Species**

Aggressive in their growing habits and make it hard for other plants to succeed

**Meadow Savannah**

A meadow is characterized as an open space with sparse tree canopy. The vegetation of meadow savanna is primarily grasses.

**Native Species**

A plant or animal is considered native to a region if it was not introduced by humans. It is a plant or animal that occurs in the area naturally.

**Rain Garden**

A garden designed to temporarily hold water from rain events that runs off of driveways, roofs, and lawns. They require plants that can tolerate lots of water and are often sloped inwards to hold more water.

**Understory**

The area of growth under the tree canopy on the forest floor.



# STENCIL TEMPLATES

**EAST**  **DAVISON**  
**VILLAGE**



# PLAN TEMPLATE

Use these templates to layout your edge design in a top-down (plan) and side view (section) drawing. The orange edge elements below for size reference as you draw your design layout.

Before you start drawing your plot plan, you'll want to know your property's boundaries and where you can place different features on your site. Within these boundaries, your use of the land may also be impacted by setbacks, existing buildings, and your property's relationship to city-owned streets, alleys or utility areas. For additional support:

<https://dlba-production-bucket.s3.us-east-2.amazonaws.com/cms/Plot+Plan+Instructions+-+Land+Based+Projects.pdf>

## PLAY ELEMENTS



## GATHER ELEMENTS

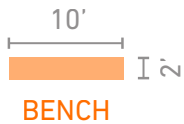

## EXCHANGE ELEMENTS

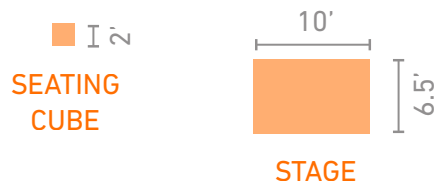

## GARDEN ELEMENTS

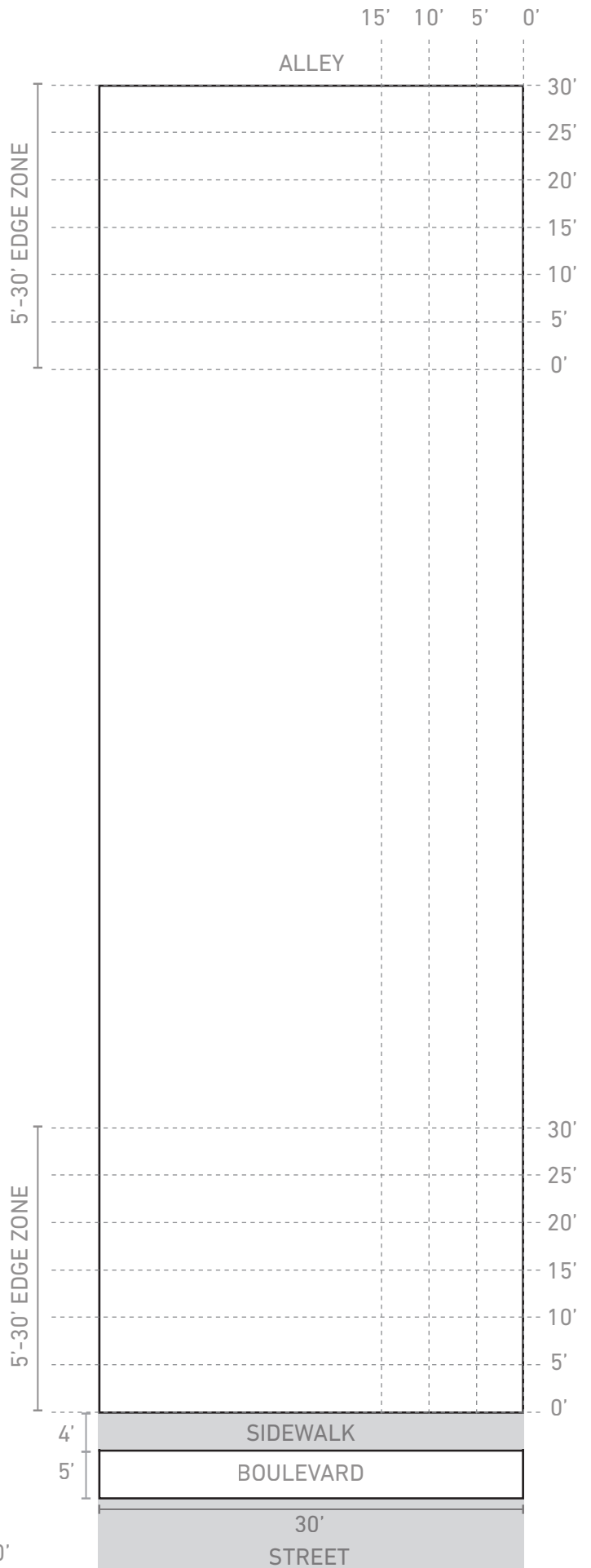
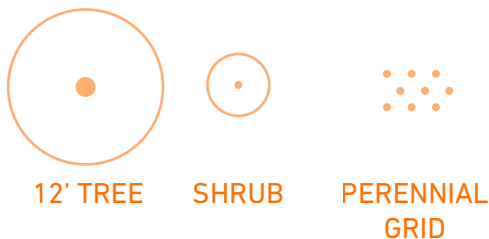

# SECTION TEMPLATE

PLAY ELEMENTS

GATHER ELEMENTS

EXCHANGE ELEMENTS

GARDEN ELEMENTS

